

---

ROBOTICS

# Product manual

## DressPack IRB 6710



Trace back information:  
Workspace 24D version a11  
Checked in 2024-12-20  
Skribenta version 5.6.018

**Product manual**  
**DressPack IRB 6710**

OmniCore

Document ID: 3HAC088410-001

Revision: C

The information in this manual is subject to change without notice and should not be construed as a commitment by ABB. ABB assumes no responsibility for any errors that may appear in this manual.

Except as may be expressly stated anywhere in this manual, nothing herein shall be construed as any kind of guarantee or warranty by ABB for losses, damage to persons or property, fitness for a specific purpose or the like.

In no event shall ABB be liable for incidental or consequential damages arising from use of this manual and products described herein.

This manual and parts thereof must not be reproduced or copied without ABB's written permission.

Keep for future reference.

Additional copies of this manual may be obtained from ABB.

Original instructions.

© Copyright 2023-2024 ABB. All rights reserved.  
Specifications subject to change without notice.



# Table of contents

Overview of this manual .....	7
Product documentation .....	9
How to read the product manual .....	11
<b>1 Safety</b> .....	<b>13</b>
1.1 Safety information .....	13
1.1.1 Limitation of liability .....	13
1.1.2 Requirements on personnel .....	14
1.2 Safety signals and symbols .....	15
1.2.1 Safety signals in the manual .....	15
1.2.2 Safety symbols on manipulator labels .....	16
1.3 Robot stopping functions .....	22
1.4 Safety during installation and commissioning .....	23
1.5 Safety during operation .....	25
1.6 Safety during maintenance and repair .....	26
1.6.1 Safety during maintenance and repair .....	26
1.7 Safety during troubleshooting .....	27
1.8 Safety during decommissioning .....	28
<b>2 Technical data</b> .....	<b>29</b>
2.1 Reference .....	29
<b>3 Installation</b> .....	<b>31</b>
3.1 Introduction to installation and commissioning .....	31
3.2 Overview .....	32
3.3 Fitting the cable package attachments .....	33
3.3.1 DressPack cable package attachments axis 1-3 .....	33
3.3.1.1 Fitting attachments of the lower arm MH .....	33
3.3.1.2 Fitting attachments of the lower arm SW .....	37
3.3.2 DressPack cable package attachments axis 3-6 .....	43
3.3.2.1 Fitting attachments of the upper arm MH3 .....	43
3.3.2.2 Fitting attachments of the LeanID MH /LeanID SW .....	49
3.4 Fitting the process turning disc .....	55
3.5 Fitting DressPack cable packages .....	58
3.5.1 DressPack cable packages axis 1-3 .....	58
3.5.1.1 Fitting the lower arm MH cable package .....	58
3.5.1.2 Fitting the lower arm SW cable package .....	67
3.5.2 DressPack cable packages axis 3-6 .....	76
3.5.2.1 Fitting the upper arm MH3 cable package .....	76
3.5.2.2 Fitting the LeanID MH / LeanID SW cable package .....	83
3.6 Installation of cabling in MH / SW LID Empty Conduit (option 3326-30 / 3326-50) .....	94
3.7 Inspection, DressPack lower arm .....	99
3.8 Inspection, DressPack upper arm .....	100
3.9 Expected lifetime of the integrated DressPack cable package .....	102
3.10 DressPack adjustments .....	103
3.10.1 Adjustments of the cable package - upper arm MH3 .....	103
3.10.2 Inspection during programming and test-running .....	104
3.11 DressPack arm load parameters .....	106
3.11.1 DressPack - arm load parameters and LoadId .....	106
3.12 DressPack floor .....	109
3.12.1 Installation of DressPack floor .....	109
3.12.2 Inspection, DressPack floor .....	112
3.13 Test run after installation, maintenance, or repair .....	113

# Table of contents

---

<b>4</b>	<b>Maintenance</b>	<b>115</b>
4.1	Introduction .....	115
4.2	Maintenance schedule and component life .....	116
4.2.1	Maintenance schedule .....	116
4.3	Inspection activities .....	118
4.3.1	Preventive inspection of all cables, DressPack .....	118
4.3.2	Preventive inspection, DressPack upper arm .....	120
4.4	Cleaning activities .....	124
4.4.1	Cleaning, DressPack upper arm .....	124
<b>5</b>	<b>Repair</b>	<b>127</b>
5.1	Introduction .....	127
5.2	DressPack cable packages axis 1-3 .....	128
5.2.1	Replacing the lower arm MH cable package .....	128
5.2.2	Replacing the lower arm SW cable package .....	134
5.3	DressPack cable packages axis 3-6 .....	139
5.3.1	Replacing the upper arm MH3 cable package .....	139
5.3.2	Replacing the LeanID MH / LeanID SW cable package .....	143
5.4	Protection hose .....	150
5.4.1	Replacing the protection hose for upper arm MH3 cable package .....	150
5.4.2	Replacing the protection hose for LeanID MH cable package .....	158
<b>6</b>	<b>Decommissioning</b>	<b>171</b>
6.1	Environmental information .....	171
<b>7</b>	<b>Reference information</b>	<b>173</b>
7.1	Introduction .....	173
7.2	Unit conversion .....	174
7.3	Screw joints .....	175
7.4	Weight specifications .....	178
7.5	Toolkits, DressPack .....	179
7.6	Lifting accessories and lifting instructions .....	181
<b>8</b>	<b>Spare parts</b>	<b>183</b>
8.1	Introduction .....	183
8.2	DressPack lower arm MH cable package .....	184
8.3	DressPack lower arm SW cable package .....	185
8.4	DressPack upper arm MH3 cable package .....	186
8.5	DressPack LeanID MH cable package .....	187
8.6	DressPack LeanID SW cable package .....	188
8.7	Connection kits .....	189
8.8	DressPack floor .....	190
	<b>Index</b>	<b>191</b>

# Overview of this manual

---

## About this manual

This manual contains instructions for:

- mechanical and electrical installation of the DressPack IRB 6710
- maintenance of the DressPack IRB 6710
- mechanical and electrical repair of the DressPack IRB 6710

The robot described in this manual has the following protection types:

- *Standard*
  - *Foundry Plus*
- 

## Product manual scope

The manual covers all variants and designs of the DressPack IRB 6710. Some variants and designs may have been removed from the business offer and are no longer available for purchase.

---

## Usage

This manual should be used during:

- installation and commissioning, from lifting the product to its work site and securing it to the foundation, to making it ready for operation
- maintenance work
- repair work
- decommissioning work



### Note

It is the responsibility of the integrator to conduct a risk assessment of the final application.

It is the responsibility of the integrator to provide safety and user guides for the robot system.

---

## Who should read this manual?

This manual is intended for:

- installation personnel
  - maintenance personnel
  - repair personnel.
- 

## Prerequisites

A maintenance/repair/installation craftsman working with an ABB robot must:

- be trained by ABB and have the required knowledge of mechanical and electrical installation/repair/maintenance work.
  - be trained to respond to emergencies or abnormal situations.
- 

*Continues on next page*

## References

Documentation referred to in the manual, is listed in the table below.

Document name	Document ID
<i>Product manual - IRB 6710</i>	<i>3HAC085695-001</i>
<i>Product manual, spare parts - IRB 6710</i>	<i>3HAC085696-001</i>
<i>Product specification - IRB 6710</i>	<i>3HAC085703-001</i>
<i>Product manual - OmniCore V250XT Type B</i>	<i>3HAC087112-001</i>
<i>Product manual - OmniCore V400XT</i>	<i>3HAC081697-001</i>
<i>Circuit diagram - IRB 6710/IRB 6720/IRB 6730/IRB 6740</i>	<i>3HAC086333-001</i>
<i>Circuit diagram - DressPack IRB 6710 / IRB 6720 / IRB 6730 / IRB 6740</i>	<i>3HAC087933-001</i>
<i>Technical reference manual - System parameters</i>	<i>3HAC065041-001</i>
<i>Operating manual - Integrator's guide OmniCore</i>	<i>3HAC065037-001</i>

## Revisions

Revision	Description
A	First edition.
B	Published in release 24A. The following updates are made in this revision: <ul style="list-style-type: none"><li>• Added more specific information about materials, tightening torque and lubrication for couplings.</li><li>• Changed article numbers for CP/CS floor cables.</li></ul>
C	Published in release 24D. The following updates are made in this revision: <ul style="list-style-type: none"><li>• Added 22 m floor cable length for parallel, Ethernet and DeviceNet floor cables.</li><li>• Sections 3.2 Overview and 3.11.1 Arm load parameters for material handling are updated with information about exclusion of upper arm load in simulations for lower arm DressPack.</li></ul>

---

# Product documentation

---

## Categories for user documentation from ABB Robotics

The user documentation from ABB Robotics is divided into a number of categories. This listing is based on the type of information in the documents, regardless of whether the products are standard or optional.



### Tip

All documents can be found via myABB Business Portal, [www.abb.com/myABB](http://www.abb.com/myABB).

---

## Product manuals

Manipulators, controllers, DressPack, and most other hardware is delivered with a **Product manual** that generally contains:

- Safety information.
- Installation and commissioning (descriptions of mechanical installation or electrical connections).
- Maintenance (descriptions of all required preventive maintenance procedures including intervals and expected life time of parts).
- Repair (descriptions of all recommended repair procedures including spare parts).
- Calibration.
- Troubleshooting.
- Decommissioning.
- Reference information (safety standards, unit conversions, screw joints, lists of tools).
- Spare parts list with corresponding figures (or references to separate spare parts lists).
- References to circuit diagrams.

---

## Technical reference manuals

The technical reference manuals describe reference information for robotics products, for example lubrication, the RAPID language, and system parameters.

---

## Application manuals

Specific applications (for example software or hardware options) are described in **Application manuals**. An application manual can describe one or several applications.

An application manual generally contains information about:

- The purpose of the application (what it does and when it is useful).
- What is included (for example cables, I/O boards, RAPID instructions, system parameters, software).
- How to install included or required hardware.
- How to use the application.

*Continues on next page*

- Examples of how to use the application.

---

### Operating manuals

The operating manuals describe hands-on handling of the products. The manuals are aimed at those having first-hand operational contact with the product, that is production cell operators, programmers, and troubleshooters.

# How to read the product manual

---

## Reading the procedures

The procedures contain all information required for the installation or service activity and can be printed out separately when needed for a certain service procedure.

## Safety information

The manual includes a separate safety chapter that must be read through before proceeding with any service or installation procedures. All procedures also include specific safety information when dangerous steps are to be performed.

Read more in the chapter [Safety on page 13](#).

## Illustrations

The product is illustrated with general figures that does not take painting or protection type in consideration.

Likewise, certain work methods or general information that is valid for several product models, can be illustrated with illustrations that show a different product model than the one that is described in the current manual.

**This page is intentionally left blank**



# 1 Safety

## 1.1 Safety information

### 1.1.1 Limitation of liability

---

#### Limitation of liability

Any information given in this manual regarding safety must not be construed as a warranty by ABB that the industrial robot will not cause injury or damage even if all safety instructions are complied with.

The information does not cover how to design, install and operate a robot system, nor does it cover all peripheral equipment that can influence the safety of the robot system.

In particular, liability cannot be accepted if injury or damage has been caused for any of the following reasons:

- Use of the robot in other ways than intended.
- Incorrect operation or maintenance.
- Operation of the robot when the safety devices are defective, not in their intended location or in any other way not working.
- When instructions for operation and maintenance are not followed as intended.
- Non-authorized design modifications of the robot.
- Repairs on the robot and its spare parts carried out by in-experienced or non-qualified personnel.
- Foreign objects.
- Force majeure.

---

#### Spare parts and equipment

ABB supplies original spare parts and equipment which have been tested and approved for their intended use. The installation and/or use of non-original spare parts and equipment can negatively affect the safety, function, performance, and structural properties of the robot. ABB is not liable for damages caused by the use of non-original spare parts and equipment.

# 1 Safety

---

## 1.1.2 Requirements on personnel

### 1.1.2 Requirements on personnel

---

#### General

Only personnel with appropriate training are allowed to install, maintain, service, repair, and use the robot. This includes electrical, mechanical, hydraulics, pneumatics, and other hazards identified in the risk assessment.

Persons who are under the influence of alcohol, drugs or any other intoxicating substances are not allowed to install, maintain, service, repair, or use the robot.

The plant liable must make sure that the personnel is trained on the robot, and on responding to emergency or abnormal situations.

---

#### Personal protective equipment

Use personal protective equipment, as stated in the instructions.

## 1.2 Safety signals and symbols

### 1.2.1 Safety signals in the manual







#### Introduction to safety signals

This section specifies all safety signals used in the user manuals. Each signal consists of:

- A caption specifying the hazard level (DANGER, WARNING, or CAUTION) and the type of hazard.
- Instruction about how to reduce the hazard to an acceptable level.
- A brief description of remaining hazards, if not adequately reduced.

#### Hazard levels

The table below defines the captions specifying the hazard levels used throughout this manual.

Symbol	Designation	Significance
	DANGER	Signal word used to indicate an imminently hazardous situation which, if not avoided, will result in serious injury.
	WARNING	Signal word used to indicate a potentially hazardous situation which, if not avoided, could result in serious injury.
	ELECTRICAL SHOCK	Signal word used to indicate a potentially hazardous situation related to electrical hazards which, if not avoided, could result in serious injury.
	CAUTION	Signal word used to indicate a potentially hazardous situation which, if not avoided, could result in slight injury.
	NOTE	Signal word used to indicate important facts and conditions.
	TIP	Signal word used to indicate where to find additional information or how to do an operation in an easier way.

# 1 Safety

## 1.2.2 Safety symbols on manipulator labels

### 1.2.2 Safety symbols on manipulator labels

#### Introduction to symbols

This section describes safety symbols used on labels (stickers) on the manipulator. Symbols are used in combinations on the labels, describing each specific warning. The descriptions in this section are generic, the labels can contain additional information such as values.



#### Note

The symbols on the labels on the product must be observed. Additional symbols added by the integrator must also be observed.



#### Types of symbols

Both the manipulator and the controller are marked with symbols, containing important information about the product. This is important for all personnel handling the robot, for example during installation, service, or operation.



The safety labels are language independent, they only use graphics. See [Symbols on safety labels on page 16](#).

The information labels can contain information in text.

#### Symbols on safety labels

Symbol	Description
 xx0900000812	<b>Warning!</b> Warns that an accident <i>may</i> occur if the instructions are not followed that can lead to serious injury, possibly fatal, and/or great damage to the product. It applies to warnings that apply to danger with, for example, contact with high voltage electrical units, explosion or fire risk, risk of poisonous gases, risk of crushing, impact, fall from height, etc.
 xx0900000811	<b>Caution!</b> Warns that an accident may occur if the instructions are not followed that can result in injury and/or damage to the product. It also applies to warnings of risks that include burns, eye injury, skin injury, hearing damage, crushing or slipping, tripping, impact, fall from height, etc. Furthermore, it applies to warnings that include function requirements when fitting and removing equipment where there is a risk of damaging the product or causing a breakdown.
 xx0900000839	<b>Prohibition</b> Used in combinations with other symbols.

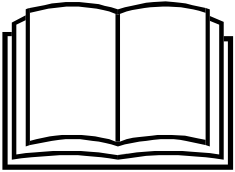
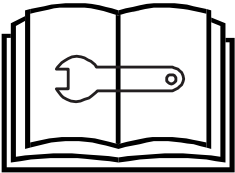
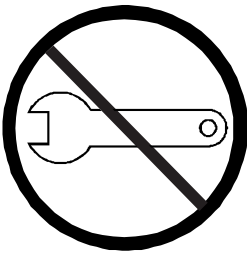
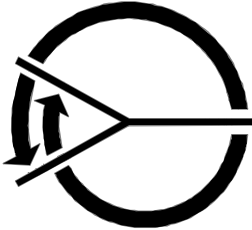

Continues on next page

Symbol	Description
 <p>xx0900000813</p>	<p><b>See user documentation</b>            Read user documentation for details.            Which manual to read is defined by the symbol:</p> <ul style="list-style-type: none"> <li>No text: <i>Product manual</i>.</li> </ul>
 <p>xx0900000816</p>	<p><b>Before disassembly, see product manual</b></p>
 <p>xx0900000815</p>	<p><b>Do not disassemble</b>            Disassembling this part can cause injury.</p>
 <p>xx0900000814</p>	<p><b>Extended rotation</b>            This axis has extended rotation (working area) compared to standard.</p>
 <p>xx0900000808</p>	<p><b>Brake release</b>            Pressing this button will release the brakes. This means that the robot arm can fall down.</p>

# 1 Safety

## 1.2.2 Safety symbols on manipulator labels

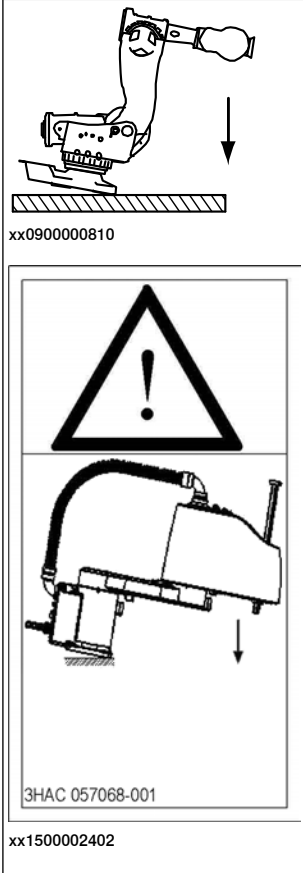
Continued

Symbol	Description
 <p>xx0900000810</p> <p>3HAC 057068-001</p> <p>xx1500002402</p>	<p><b>Tip risk when loosening bolts</b> The robot can tip over if the bolts are not securely fastened.</p>
 <p>xx0900000817</p>	<p><b>Crush</b> Risk of crush injuries.</p>



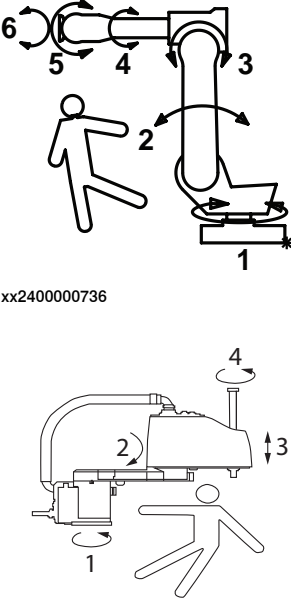
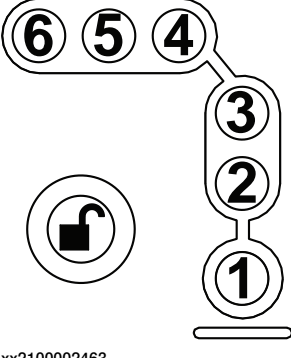



Continues on next page

Symbol	Description
 <p>xx0900000818</p> <p>xx1300001087</p>	<p><b>Heat</b> Risk of heat that can cause burns. (Both signs are used)</p>
 <p>xx2400000736</p> <p>xx1500002616</p>	<p><b>Moving robot</b> The robot can move unexpectedly.</p>
 <p>xx2100002463</p>	<p><b>Brake release buttons</b></p>

# 1 Safety

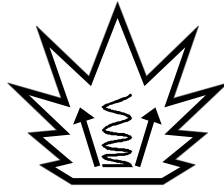

## 1.2.2 Safety symbols on manipulator labels

Continued

Symbol	Description
 <p>xx0900000821</p>	Lifting bolt
 <p>xx1000001242</p>	Adjustable chain sling with shortener
 <p>xx0900000822</p>	Lifting of robot
 <p>xx0900000823</p>	Oil Can be used in combination with prohibition if oil is not allowed.
 <p>xx0900000824</p>	Mechanical stop
 <p>xx1000001144</p>	No mechanical stop
 <p>xx0900000825</p>	Stored energy Warns that this part contains stored energy. Used in combination with <i>Do not disassemble</i> symbol.

Continues on next page

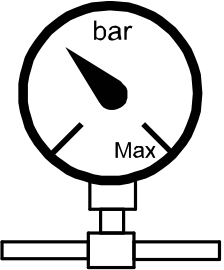
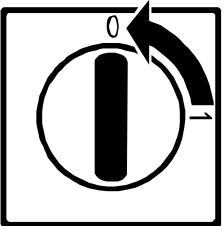

Symbol	Description
 <p data-bbox="451 589 563 607">xx0900000826</p>	<p data-bbox="759 315 863 338"><b>Pressure</b></p> <p data-bbox="759 349 1436 405">Warns that this part is pressurized. Usually contains additional text with the pressure level.</p>
 <p data-bbox="451 882 563 900">xx0900000827</p>	<p data-bbox="759 647 991 669"><b>Shut off with handle</b></p> <p data-bbox="759 680 1190 703">Use the power switch on the controller.</p>
 <p data-bbox="451 1189 563 1207">xx1400002648</p>	<p data-bbox="759 940 895 963"><b>Do not step</b></p> <p data-bbox="759 974 1436 1030">Warns that stepping on these parts can cause damage to the parts.</p>

# 1 Safety

---

## 1.3 Robot stopping functions

### 1.3 Robot stopping functions

---

#### Protective stop and emergency stop

The protective stops and emergency stops are described in the product manual for the controller.

For more information see:

- *Product manual - OmniCore V250XT Type B*
- *Product manual - OmniCore V400XT*

### 1.4 Safety during installation and commissioning

---

#### National or regional regulations

The integrator of the robot system is responsible for the safety of the robot system.

The integrator is responsible that the robot system is designed and installed in accordance with the safety requirements set forth in the applicable national and regional standards and regulations.

The integrator of the robot system is required to perform a risk assessment.

---

#### Layout

The robot integrated to a robot system shall be designed to allow safe access to all spaces during installation, operation, maintenance, and repair.

If robot movement can be initiated from an external control panel then an emergency stop must also be available.

Consider exposure to hazards, such as slipping, tripping, and falling.

Hazards due to the working position and posture for a person working with or near the robot shall be considered.

Hazards due to noise emission from the robot needs to be considered.

Consider hazards from other equipment in the robot system, for example, that guards remain active until identified hazards are reduced to an acceptable level.

---

#### Allergenic material

See [Environmental information on page 171](#) for specification of allergenic materials in the product, if any.

---

#### Securing the robot to the foundation

The robot must be properly fixed to its foundation/support, as described in the respective product manual.

When the robot is installed at a height, hanging, or other than mounted directly on the floor, there will be additional hazards.

---

#### Using lifting accessories and other external equipment

Ensure that all equipment used during installation, service and all handling of the robot are in correct condition for the intended use.

---

#### Electrical safety

Incoming mains must be installed to fulfill national regulations.

The power supply wiring to the robot must be sufficiently fused and if necessary, it must be possible to disconnect it manually from the mains power.

The power to the robot must be turned off with the main switch and the mains power disconnected when performing work inside the controller cabinet. Lock and tag shall be considered.

Harnesses between controller and manipulator shall be fixed and protected to avoid tripping and wear.

---

*Continues on next page*

# 1 Safety

---

## 1.4 Safety during installation and commissioning

*Continued*

Wherever possible, power on/off or rebooting the robot controller shall be performed with all persons outside the safeguarded space.



### Note

Use a CARBON DIOXIDE (CO<sub>2</sub>) extinguisher in the event of a fire in the robot.

---

### Safety devices

The integrator is responsible for that the safety devices necessary to protect people working with the robot system are designed and installed correctly.

When integrating the robot with external devices to a robot system:

- The integrator of the robot system must ensure that emergency stop functions are interlocked in accordance with applicable standards.
- The integrator of the robot system must ensure that safety functions are interlocked in accordance with applicable standards.

---

### Other hazards

The risk assessment should also consider other hazards arising from the application, such as, but not limited to:

- Water
- Compressed air
- Hydraulics

End-effector hazards require particular attention for applications which involve close human collaboration with the robot.

---

### Verify the safety functions

Before the robot system is put into operation, verify that the safety functions are working as intended and that any remaining hazards identified in the risk assessment are mitigated to an acceptable level.

### 1.5 Safety during operation

#### Automatic operation

Verify the application in the operating mode manual reduced speed, before changing mode to automatic and initiating automatic operation.

#### Unexpected movement of robot arm



#### **WARNING**

Hazards due to the use of brake release devices and/or gravity beneath the manipulator shall be considered.

# 1 Safety

---

## 1.6.1 Safety during maintenance and repair

## 1.6 Safety during maintenance and repair

### 1.6.1 Safety during maintenance and repair

---

#### General

Corrective maintenance must only be carried out by personnel trained on the robot. Maintenance or repair must be done with all electrical, pneumatic, and hydraulic power switched off, that is, no remaining hazards.

Hazards due to stored mechanical energy in the manipulator for the purpose of counterbalancing axes must be considered before maintenance or repair.

Never use the robot as a ladder, which means, do not climb on the controller, manipulator, including motors, or other parts. There are hazards of slipping and falling. The robot might be damaged.

Make sure that there are no tools, loose screws, turnings, or other unexpected parts remaining after maintenance or repair work.

When the work is completed, verify that the safety functions are working as intended.

---

#### Hot surfaces

Surfaces can be hot after running the robot, and touching these may result in burns. Allow the surfaces to cool down before maintenance or repair.

---

#### Related information

See also the safety information related to installation and operation.

### 1.7 Safety during troubleshooting

#### General

When troubleshooting requires work with power switched on, special considerations must be taken:

- Safety circuits might be muted or disconnected.
- Electrical parts must be considered as *live*.
- The manipulator can move unexpectedly at any time.



#### **DANGER**

Troubleshooting on the controller while powered on must be performed by personnel trained by ABB or by ABB field engineers.



#### **CAUTION**

Risk of hot surfaces that can cause burns.

A risk assessment must be done to address both robot and robot system specific hazards.

#### Related information

See also the safety information related to installation, operation, maintenance, and repair.

# 1 Safety

---

## 1.8 Safety during decommissioning

### 1.8 Safety during decommissioning

---

#### General

See section [Decommissioning on page 171](#).

If the robot is decommissioned for storage, take extra precaution to reset safety devices to delivery status.



## 2 Technical data

### 2.1 Reference

---

#### Technical data

See technical data for the DressPack in the product specification for the manipulator.

**This page is intentionally left blank**

## 3 Installation

### 3.1 Introduction to installation and commissioning

---

#### General

This chapter contains assembly instructions and information for installing the DressPack IRB 6710 at the working site.

See also the product manual for the robot controller.

The installation must be done by qualified installation personnel in accordance with the safety requirements set forth in the applicable national and regional standards and regulations.

The technical data is detailed in section [Technical data on page 29](#).

---

#### Safety information

Before any installation work is commenced, all safety information must be observed. There are general safety aspects that must be read through, as well as more specific safety information that describes the danger and safety risks when performing the procedures. Read the chapter [Safety on page 13](#) before performing any installation work.

## 3 Installation

---

### 3.2 Overview

### 3.2 Overview

---

#### General

Installing, programming and operating the ABB DressPack product program may be a complex task as each application instance is very specific. The product is designed to fit a wide variety of applications, and must be adapted to each in order to maximize life and function.

The generic installation procedure is described below.



#### CAUTION

The cabling is sensitive to mechanical damage. Handle it with care to avoid damage to the cabling or the connector, avoid any kind of tilt or skew.

---

#### Effects on arm load and performance



#### Note

The extra weight of the DressPack products will affect the arm load data and the performance of the robot. The effect differs depending on which type of DressPack product. See [DressPack - arm load parameters and LoadId](#).

---

#### How to simulate an only base to axis 3 material handling



#### Note

To simulate an only base to axis 3 material handling DressPack, use the MH3 robot variant and hide the upper arm CAD models. Modification of the arm loads might be needed.

### 3.3 Fitting the cable package attachments

#### 3.3.1 DressPack cable package attachments axis 1-3

##### 3.3.1.1 Fitting attachments of the lower arm MH

###### Location of the attachments

The location of the attachments of the lower arm MH cable package are shown in the figure.

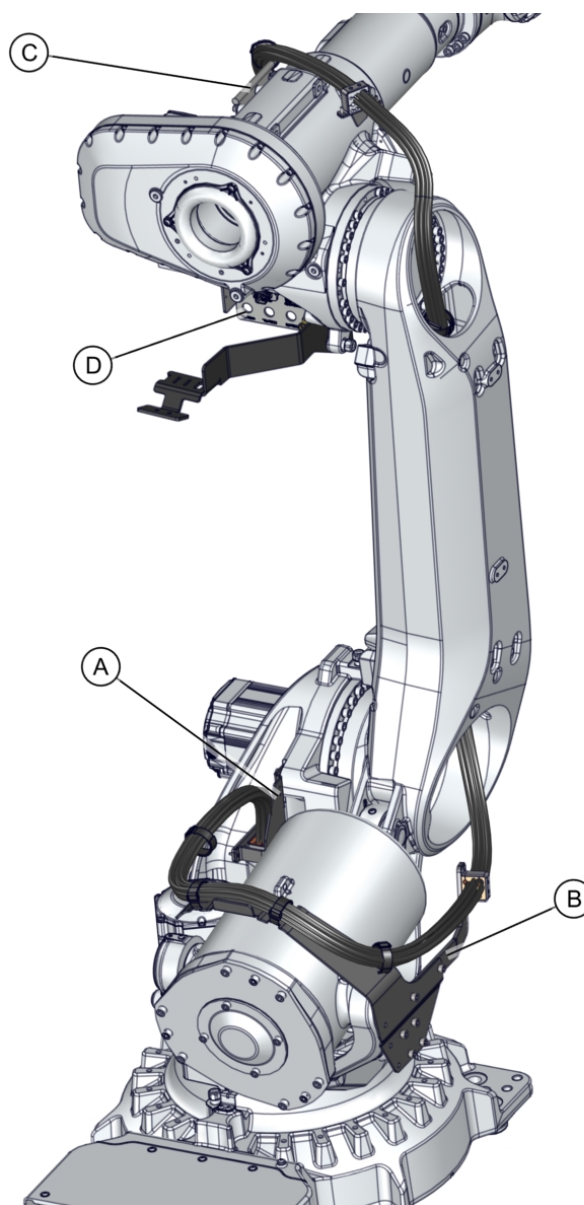

xx2300001009

A	Axis-1 bracket
B	Side bracket

*Continues on next page*

### 3 Installation

#### 3.3.1.1 Fitting attachments of the lower arm MH

Continued

C	Cable guide
D	Axis-3 connection and mounting plate

#### Required spare parts



#### Note

The spare part numbers that are listed in the table can be out of date. See the latest spare parts of the DressPack IRB 6710 via myABB Business Portal, [www.abb.com/myABB](http://www.abb.com/myABB).

Spare part	Article number	Note
Cable pack attachments	Contact ABB	

#### Required service parts

Consumable	Article number	Note
Locking liquid	-	Loctite 2400 (or equivalent Loctite 243)

#### Required tools and equipment

Equipment, etc.	Article number	Note
Standard toolkit	-	Content is defined in section <a href="#">Standard toolkit on page 179</a> .

#### Fitting the cable attachments - lower arm MH

Use this procedure to install the attachments.

	Action	Note
1	Move the robot to a comfortable working position.	
2	 <b>DANGER</b> Turn off all: <ul style="list-style-type: none"><li>• electric power supply</li><li>• hydraulic pressure supply</li><li>• air pressure supply</li></ul> to the robot, before entering the safe-guarded space.	

Continues on next page

#### 3.3.1.1 Fitting attachments of the lower arm MH Continued

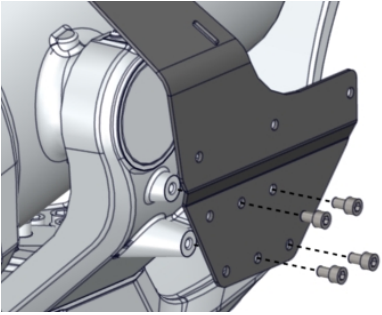
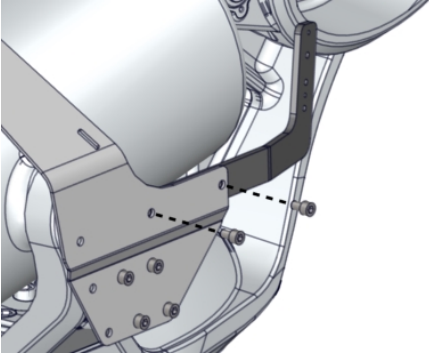
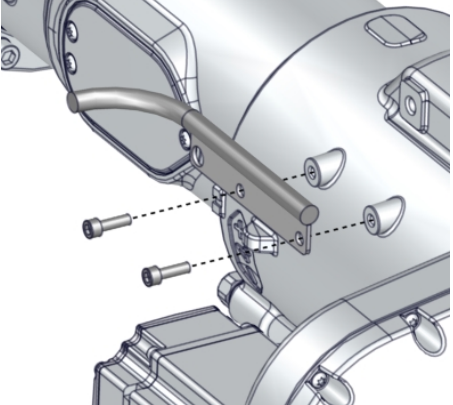
	Action	Note
3	Fit the side bracket to the cradle. Use locking liquid on the attachment screws.	<p>Locking liquid: Loctite 2400 (or equivalent Loctite 243)</p>  <p>xx2300001011</p> <p>Hex socket head cap screw: M10x16 stainless steel A2-70 (4 pcs)</p>
4	Fit the side bracket arm. Use locking liquid on the attachment screws.	<p>Locking liquid: Loctite 2400 (or equivalent Loctite 243)</p>  <p>xx2300001012</p> <p>Hex socket head cap screw: M10x16 stainless steel A2-70 (2 pcs)</p>
5	Fit the cable guide to the arm house. Use locking liquid on the attachment screws.	<p>Locking liquid: Loctite 2400 (or equivalent Loctite 243)</p>  <p>xx2300001035</p> <p>Hexagon socket head cap screw: M8x25 (2 pcs)</p>

*Continues on next page*

## 3 Installation

### 3.3.1.1 Fitting attachments of the lower arm MH

*Continued*

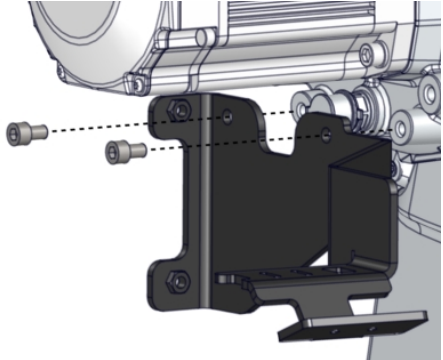
	Action	Note
6	Remove the plastic plugs, if fitted, and fit the axis-3 mounting plate. Use locking liquid on the attachment screws.	<p data-bbox="954 315 1409 371">Locking liquid: Loctite 2400 (or equivalent Loctite 243)</p>  <p data-bbox="954 752 1062 770">xx2300001036</p> <p data-bbox="954 786 1409 842">Hex socket head cap screw: M10x16 8.8-A3F (2 pcs)</p>



## 3.3.1.2 Fitting attachments of the lower arm SW

## Location of the attachments

The location of the attachments of the lower arm SW cable package are shown in the figure.

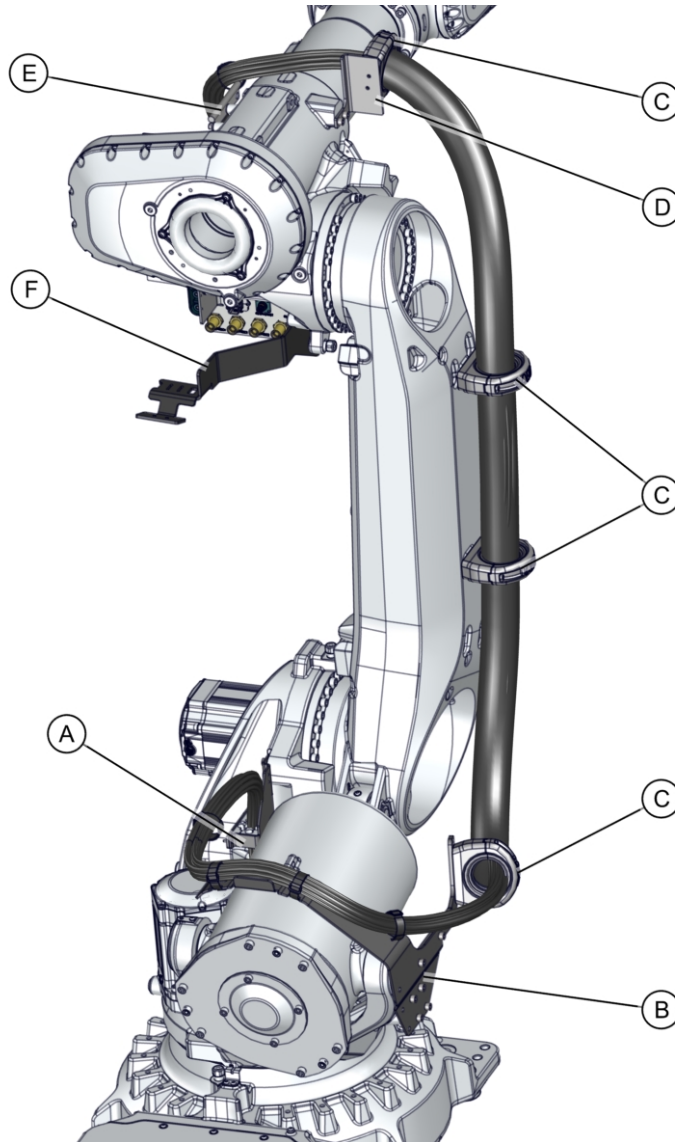

xx2300001007

A	Axis-1 bracket
B	Side bracket
C	Ball joint housing (4 pcs)
D	Arm house bracket
E	Cable guide
F	Axis-3 mounting plate

*Continues on next page*

### 3 Installation

#### 3.3.1.2 Fitting attachments of the lower arm SW

Continued

#### Required spare parts



#### Note

The spare part numbers that are listed in the table can be out of date. See the latest spare parts of the DressPack IRB 6710 via myABB Business Portal, [www.abb.com/myABB](http://www.abb.com/myABB).

Spare part	Article number	Note
Cable pack attachments	Contact ABB	

#### Required service parts

Consumable	Article number	Note
Locking liquid	-	Loctite 2400 (or equivalent Loctite 243)

#### Required tools and equipment

Equipment, etc.	Article number	Note
Standard toolkit	-	Content is defined in section <a href="#">Standard toolkit on page 179</a> .

#### Fitting the cable attachments - lower arm SW

Use this procedure to install the attachments.

	Action	Note
1	Move the robot to a comfortable working position.	
2	 <b>DANGER</b> Turn off all: <ul style="list-style-type: none"><li>• electric power supply</li><li>• hydraulic pressure supply</li><li>• air pressure supply</li></ul> to the robot, before entering the safeguarded space.	

Continues on next page

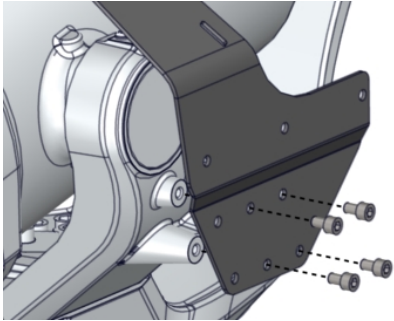
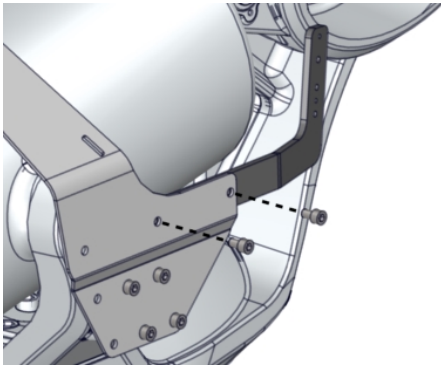
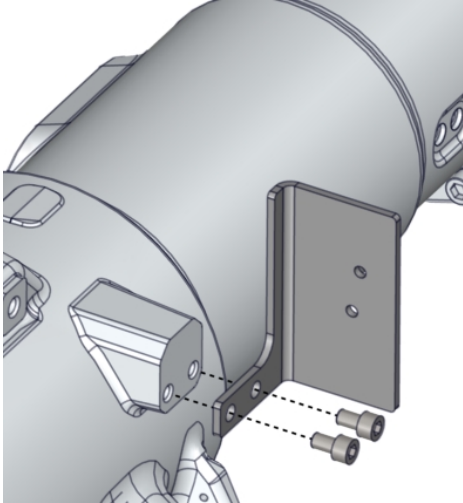
	Action	Note
3	Fit the side bracket to the cradle. Use locking liquid on the attachment screws.	<p>Locking liquid: Loctite 2400 (or equivalent Loctite 243)</p>  <p>xx2300001011</p> <p>Hex socket head cap screw: M10x16 stainless steel A2-70 (4 pcs)</p>
4	Fit the side bracket arm. Use locking liquid on the attachment screws.	<p>Locking liquid: Loctite 2400 (or equivalent Loctite 243)</p>  <p>xx2300001012</p> <p>Hex socket head cap screw: M10x16 stainless steel A2-70 (2 pcs)</p>
5	Fit the arm house bracket to the arm house. Use locking liquid on the attachment screws.	<p>Locking liquid: Loctite 2400 (or equivalent Loctite 243)</p>  <p>xx2300001034</p> <p>Hex socket head cap screw: M10x16 stainless steel A2-70 (2 pcs)</p>

*Continues on next page*

### 3 Installation

#### 3.3.1.2 Fitting attachments of the lower arm SW

*Continued*

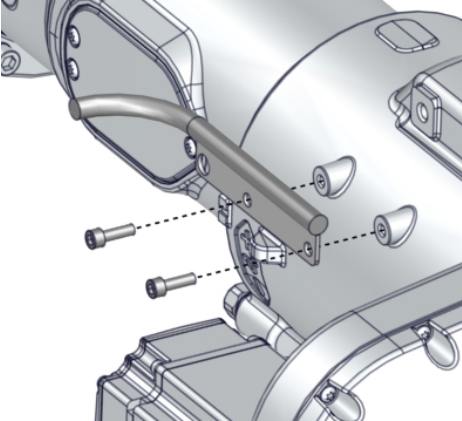
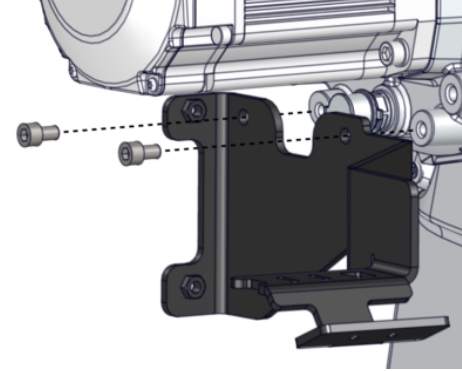
	Action	Note
6	Fit the cable guide to the arm house. Use locking liquid on the attachment screws.	<p data-bbox="943 315 1406 371">Locking liquid: Loctite 2400 (or equivalent Loctite 243)</p>  <p data-bbox="943 813 1050 831">xx2300001035</p> <p data-bbox="943 846 1390 902">Hexagon socket head cap screw: M8x25 (2 pcs)</p>
7	Remove the plastic plugs, if fitted, and fit the axis-3 mounting plate. Use locking liquid on the attachment screws.	<p data-bbox="943 918 1406 974">Locking liquid: Loctite 2400 (or equivalent Loctite 243)</p>  <p data-bbox="943 1361 1050 1379">xx2300001036</p> <p data-bbox="943 1395 1350 1451">Hex socket head cap screw: M10x16 stainless steel A2-70 (2 pcs)</p>

*Continues on next page*

#### Fitting the ball joint housing, lower part

Use this procedure to install the lower parts of the ball joint housings.

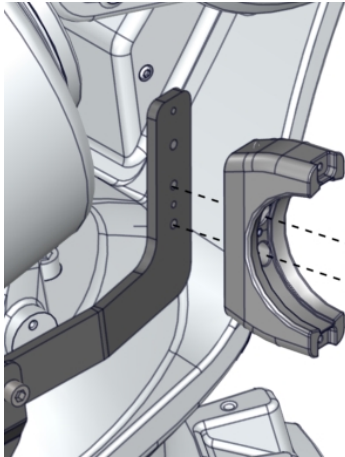
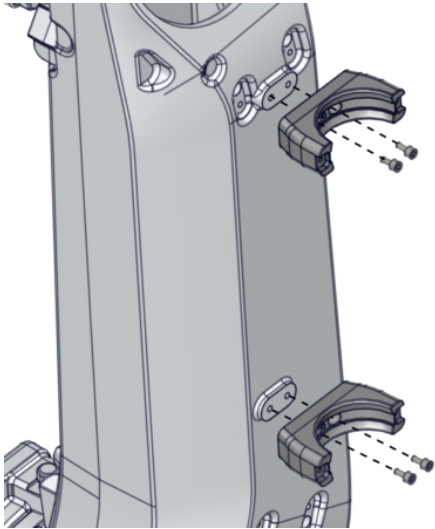
	Action	Note
1	<p>Fit the lower part of the ball joint housing to the side bracket. Use locking liquid on the attachment screws.</p>	<p>Locking liquid: Loctite 2400 (or equivalent Loctite 243)</p>  <p>xx2300001014</p> <p>Hex socket head cap screw: M8x16 A2-70 (2 pcs)</p>
2	<p>Fit the lower parts of the two ball joint housings to the lower arm. Use locking liquid on the attachment screws.</p>	<p>Locking liquid: Loctite 2400 (or equivalent Loctite 243)</p>  <p>xx2300001013</p> <p>Hex socket head cap screw: M8x16 A2-70 (2 pcs/housing)</p>

Continues on next page

### 3 Installation

#### 3.3.1.2 Fitting attachments of the lower arm SW

*Continued*

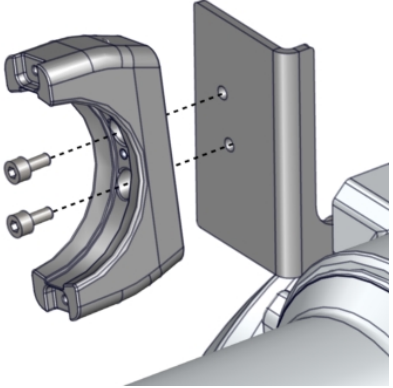
	Action	Note
3	Fit the lower part of the ball joint housing to the bracket on the arm house. Use locking liquid on the attachment screws.	Locking liquid: Loctite 2400 (or equivalent Loctite 243)  xx2300001037 Hex socket head cap screw: M8x16 A2-70 (2 pcs)

### 3.3.2 DressPack cable package attachments axis 3-6

#### 3.3.2.1 Fitting attachments of the upper arm MH3

##### Location of the attachments

The location of the attachments of the upper arm MH3 cable package are shown in the figure.

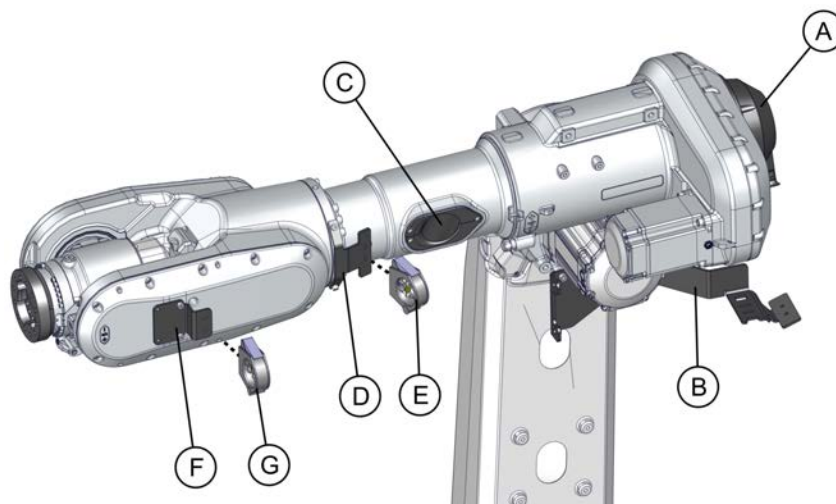

xx2300001073

A	Cover
B	Mounting plate
C	Insert
D	Wrist flange bracket
E	Ball joint housing
F	Wrist cover bracket
G	Ball joint housing

##### Required spare parts



##### Note

The spare part numbers that are listed in the table can be out of date. See the latest spare parts of the DressPack IRB 6710 via myABB Business Portal, [www.abb.com/myABB](http://www.abb.com/myABB).

Spare part	Article number	Note
Cable pack attachments	Contact ABB	

*Continues on next page*

### 3 Installation

#### 3.3.2.1 Fitting attachments of the upper arm MH3

Continued

#### Required service parts

Consumable	Article number	Note
Locking liquid	-	Loctite 2400 (or equivalent Loctite 243)

#### Required tools and equipment

Equipment, etc.	Article number	Note
Standard toolkit	-	Content is defined in section <a href="#">Standard toolkit on page 179</a> .

#### Fitting the cable attachments - upper arm MH3

##### Preparations

	Action	Note
1	Move the robot to a comfortable working position.	
2	 <b>DANGER</b> Turn off all: <ul style="list-style-type: none"> <li>• electric power supply</li> <li>• hydraulic pressure supply</li> <li>• air pressure supply</li> </ul> to the robot, before entering the safeguarded space.	

##### Fitting insert, tube and cover

The figure shows the location of the fitted insert, tube and cover in the upper arm.

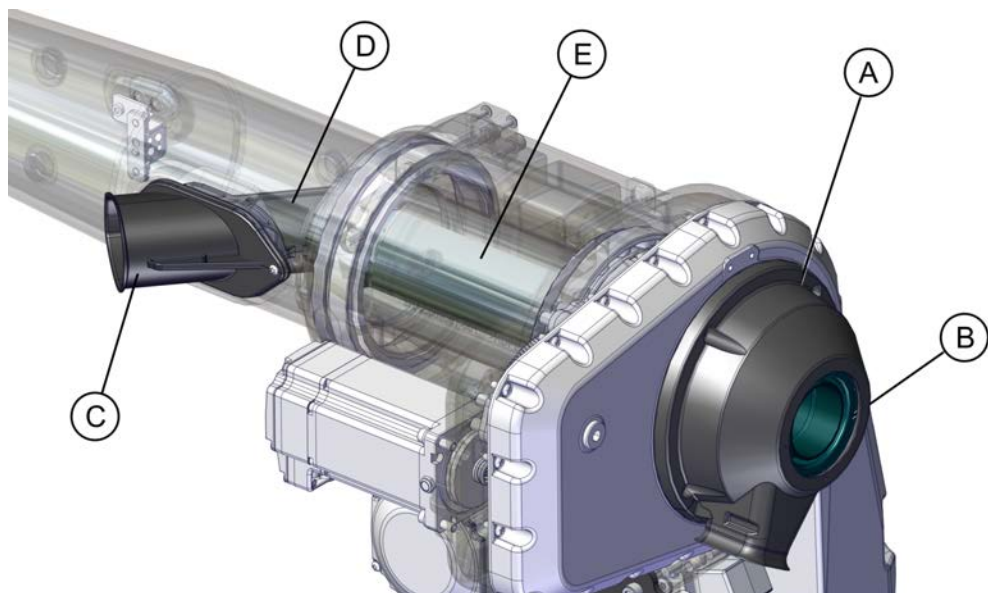

xx2100002694

A	Cover
---	-------

Continues on next page



B	Tube guiding ring
C	Cable guard (included for protection type Foundry Plus)
D	Insert
E	Tube

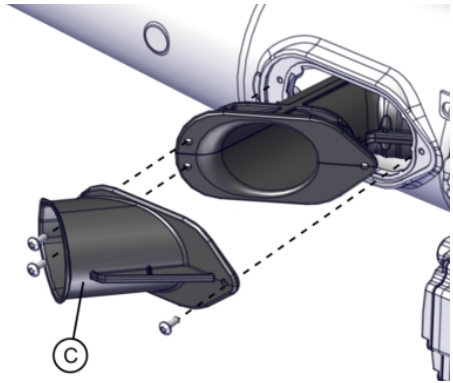
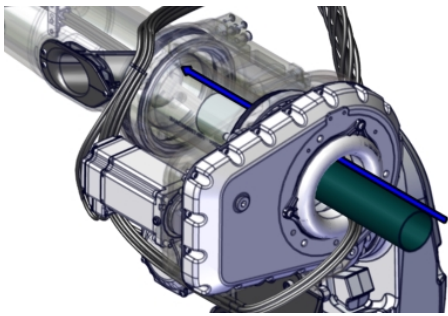
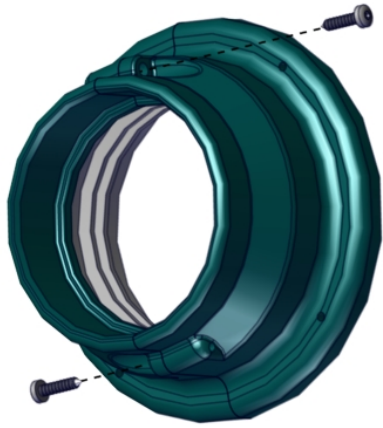

	Action	Note
1	<p>Fit the insert.</p> <p><i>Protection type Foundry Plus:</i> Also fit the cable guard (C) to the insert with the same attachment screws.</p>	<p>Locking liquid: Loctite 2400 (or equivalent Loctite 243)</p>  <p>xx2100002677</p> <p>Torx pan head screw: M6x16 A4-80 (3 pcs) <i>Protection type Foundry Plus:</i> Torx pan head screw: M6x20 A4-80 (3 pcs)</p>
2	<p>Insert the tube into the arm tube and fit it into the insert.</p>	 <p>xx2100002678</p>
3	<p>Mount the two parts of the tube guiding ring.</p>	 <p>xx2100002682</p> <p>Pan head screw: ST3.5x16 (3HAC043107-001) (2 pcs)</p>

*Continues on next page*

### 3 Installation

#### 3.3.2.1 Fitting attachments of the upper arm MH3

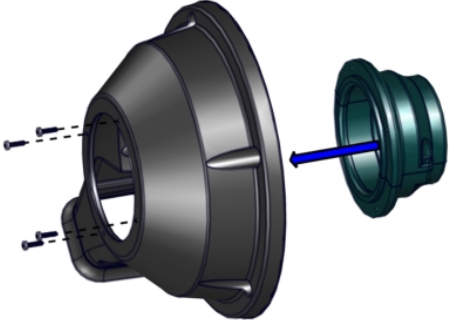
Continued

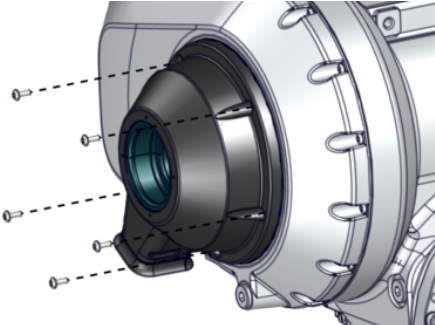
	Action	Note
4	Fit the tube guiding ring in the cover.	 <p data-bbox="943 674 1050 689">xx2300001039</p> <p data-bbox="943 703 1407 757">Pan head screw: ST3.5x16 (3HAC043107-001) (4 pcs)</p>
5	Fit the cover with the tube guiding ring fitted, on the tube and secure it to the arm house cover.   <b>Note</b> Make sure that the tube is fitted correctly in both ends, when fitting the cover.	<p data-bbox="943 775 1407 828">Locking liquid: Loctite 2400 (or equivalent Loctite 243)</p>  <p data-bbox="943 1178 1050 1193">xx2300001040</p> <p data-bbox="943 1207 1407 1258">Torx pan head screw: M6x16 Stainless steel A2-70 (5 pcs)</p>

#### Fitting the brackets

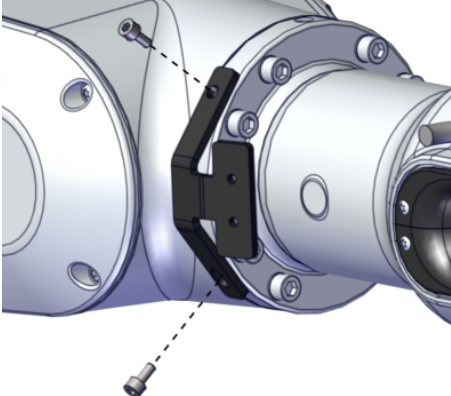
	Action	Note
1	Fit the cable bracket to the wrist flange with the attachment screws. Use locking liquid.	<p data-bbox="943 1397 1407 1451">Locking liquid: Loctite 2400 (or equivalent Loctite 243)</p>  <p data-bbox="954 1877 1061 1892">xx2100002746</p> <p data-bbox="954 1906 1407 1955">Hex socket head cap screw: M8x16 A2-70 (2 pcs)</p>

Continues on next page

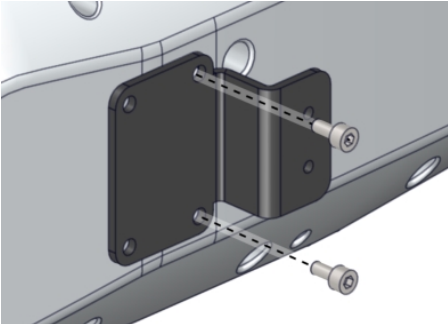
	Action	Note
2	Fit the cable bracket to the wrist cover with the attachment screws. Use locking liquid.	Locking liquid: Loctite 2400 (or equivalent Loctite 243)  xx2300001239 Hex socket head cap screw: M8x16 A2-70 (2 pcs)

#### Fitting the ball joint housings

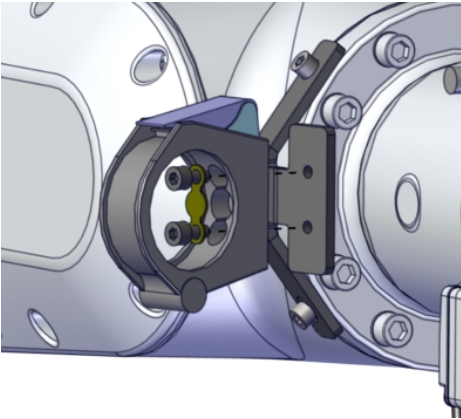
	Action	Note
1	Fit the ball joint housing to the wrist flange bracket with the attachment screws and a washer. Use locking liquid.	Locking liquid: Loctite 2400 (or equivalent Loctite 243)  xx2100002766 Hex socket head cap screw: M8x16 A2-70 (2 pcs) Washer: 3HAC028320-001

*Continues on next page*

### 3 Installation

#### 3.3.2.1 Fitting attachments of the upper arm MH3

*Continued*

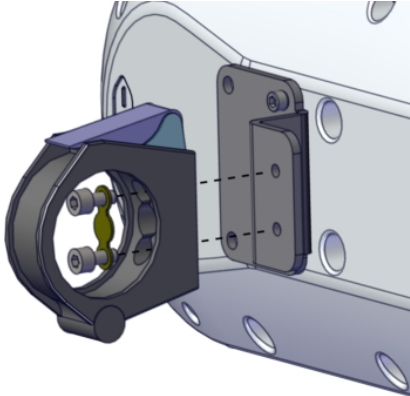
	Action	Note
2	Fit the ball joint housing to the bearing with the attachment screws and a washer. Use locking liquid.	<p data-bbox="944 315 1406 367">Locking liquid: Loctite 2400 (or equivalent Loctite 243)</p>  <p data-bbox="944 808 1050 824">xx2100002767</p> <p data-bbox="944 840 1394 896">Hex socket head cap screw: M8x16 A2-70 (2 pcs)</p> <p data-bbox="944 902 1235 920">Washer: 3HAC028320-001</p>

### 3.3.2.2 Fitting attachments of the LeanID MH /LeanID SW

#### Location of the attachments

The attachments for the LeanID MH /SW cable package are located as shown in the figure.

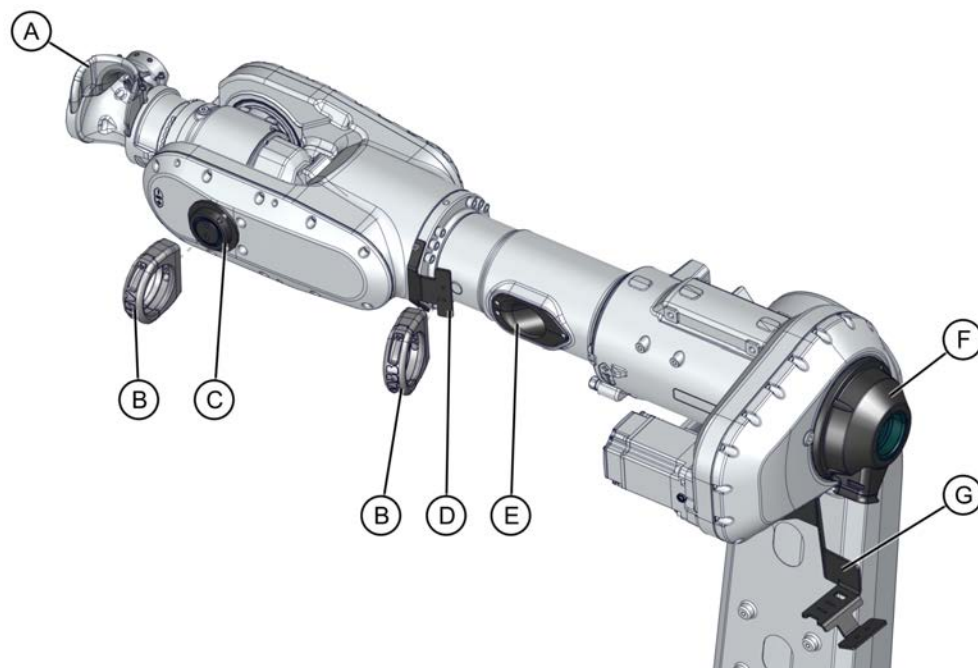

xx2300001038

A	Cable guide
B	Ball joint housing (2 pcs)
C	Bearing
D	Wrist flange bracket
E	Insert
F	Cover
G	Mounting plate

#### Required spare parts



#### Note

The spare part numbers that are listed in the table can be out of date. See the latest spare parts of the DressPack IRB 6710 via myABB Business Portal, [www.abb.com/myABB](http://www.abb.com/myABB).

Spare part	Article number	Note
Cable pack attachments	Contact ABB	

*Continues on next page*

### 3 Installation

#### 3.3.2.2 Fitting attachments of the LeanID MH /LeanID SW

*Continued*

#### Required service parts

Consumable	Article number	Note
Locking liquid	-	Loctite 2400 (or equivalent Loctite 243)

#### Required tools and equipment

Equipment, etc.	Article number	Note
Standard toolkit	-	Content is defined in section <a href="#">Standard toolkit on page 179</a> .

#### Fitting the cable attachments - LeanID MH / SW

Use these procedures to fit the cable attachments.

#### Preparations

	Action	Note
1	Move the robot to a comfortable working position.	
2	 <b>DANGER</b> Turn off all: <ul style="list-style-type: none"> <li>• electric power supply</li> <li>• hydraulic pressure supply</li> <li>• air pressure supply</li> </ul> to the robot, before entering the safe-guarded space.	

#### Fitting brackets

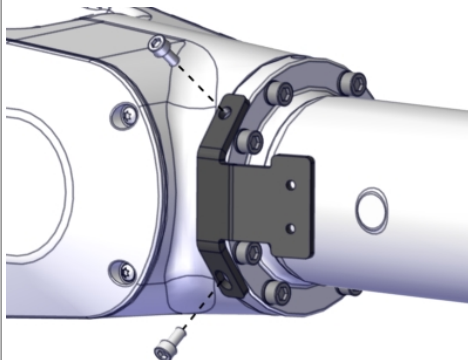
	Action	Note
1	Fit the cable bracket to the wrist flange with the attachment screws. Use locking liquid.	Locking liquid: Loctite 2400 (or equivalent Loctite 243)  <small>xx2100002675</small> Hex socket head cap screw: M8x16 A2-70 (2 pcs)

*Continues on next page*

#### 3.3.2.2 Fitting attachments of the LeanID MH /LeanID SW Continued

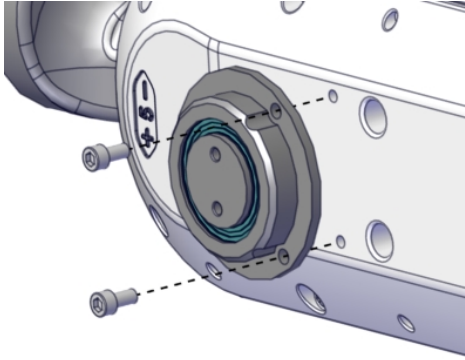
	Action	Note
2	Fit the complete bearing on the wrist cover with the attachment screws. Use locking liquid.	Locking liquid: Loctite 2400 (or equivalent Loctite 243)  xx2100002676 Hex socket head cap screw: M8x16 A2-7 0 (2 pcs)

#### Fitting insert, tube and cover

The figure shows the location of the fitted insert, tube and cover in the upper arm.

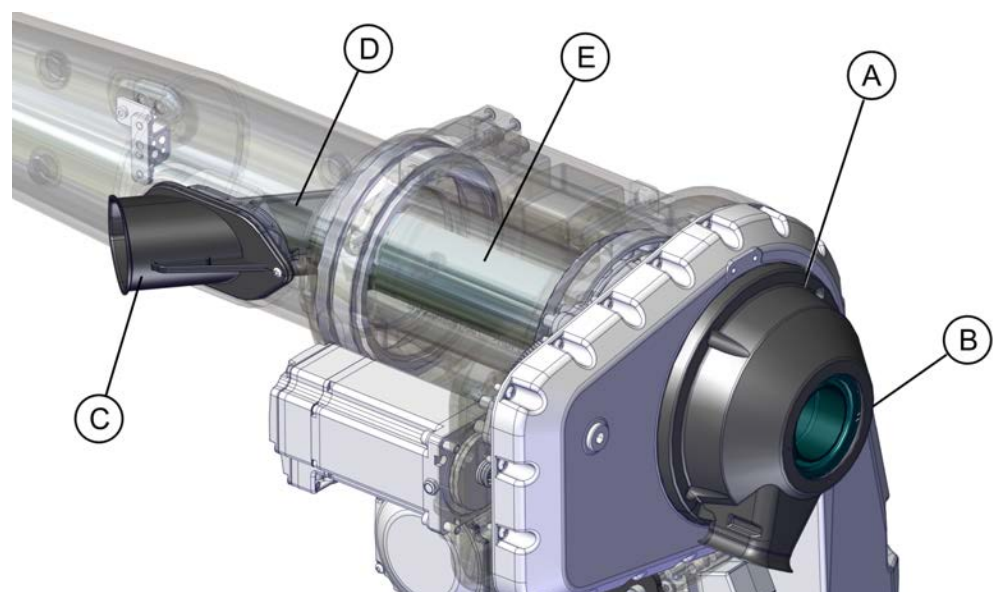

xx2100002694

A	Cover
B	Tube guiding ring
C	Cable guard (included for protection type Foundry Plus)
D	Insert
E	Tube



*Continues on next page*



### 3 Installation

#### 3.3.2.2 Fitting attachments of the LeanID MH /LeanID SW

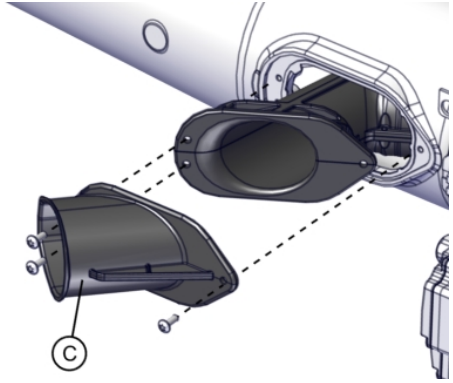
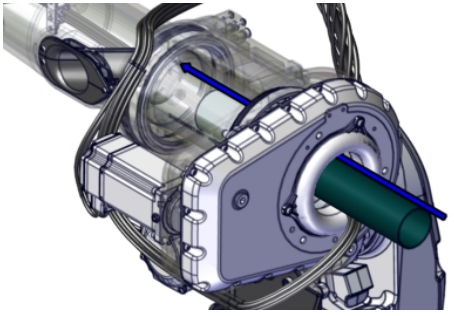
Continued

	Action	Note
1	Fit the insert. <i>Protection type Foundry Plus:</i> Also fit the cable guard (C) to the insert with the same attachment screws.	Locking liquid: Loctite 2400 (or equivalent Loctite 243)  xx2100002677 Torx pan head screw: M6x16 A4-80 (3 pcs) <i>Protection type Foundry Plus:</i> Torx pan head screw: M6x20 A4-80 (3 pcs)
2	Insert the tube into the arm tube and fit it into the insert.	 xx2100002678
3	Mount the two parts of the tube guiding ring.	 xx2100002682 Pan head screw: ST3.5x16 (3HAC043107-001) (2 pcs)

Continues on next page

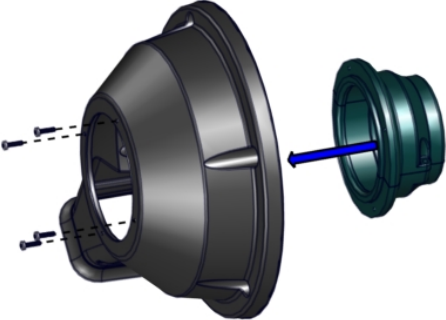
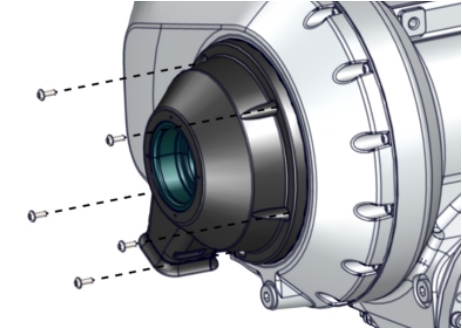

	Action	Note
4	Fit the tube guiding ring in the cover.	 <p data-bbox="975 674 1078 689">xx2300001039</p> <p data-bbox="975 703 1439 757">Pan head screw: ST3.5x16 (3HAC043107-001) (4 pcs)</p>
5	Fit the cover with the tube guiding ring fitted, on the tube and secure it to the arm house cover.   <b>Note</b> Make sure that the tube is fitted correctly in both ends, when fitting the cover.	<p data-bbox="975 775 1439 828">Locking liquid: Loctite 2400 (or equivalent Loctite 243)</p>  <p data-bbox="975 1178 1078 1193">xx2300001040</p> <p data-bbox="975 1211 1439 1265">Torx pan head screw: M6x16 Stainless steel A2-70 (5 pcs)</p>

#### Fitting the ball joint housing

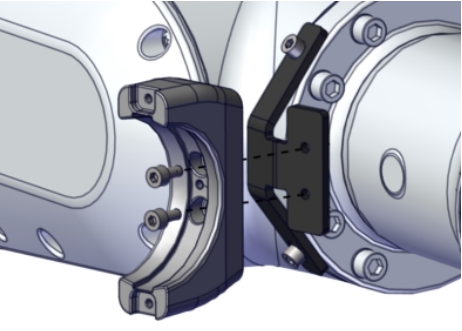
	Action	Note
1	Fit the ball joint housing to the wrist flange bracket with the attachment screws. Use locking liquid.	<p data-bbox="975 1391 1439 1444">Locking liquid: Loctite 2400 (or equivalent Loctite 243)</p>  <p data-bbox="975 1805 1078 1821">xx2100002684</p> <p data-bbox="975 1839 1439 1892">Hex socket head cap screw: M8x16 A2-70 (2 pcs)</p>

Continues on next page

### 3 Installation

#### 3.3.2.2 Fitting attachments of the LeanID MH /LeanID SW

*Continued*

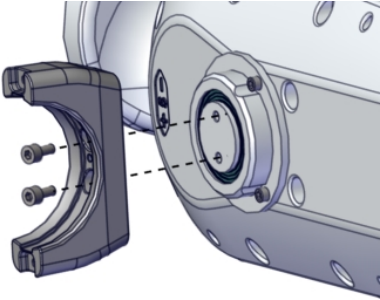
	Action	Note
2	Fit the ball joint housing to the bearing with the attachment screws. Use locking liquid.	Locking liquid: Loctite 2400 (or equivalent Loctite 243)  xx2100002686 Hex socket head cap screw: M8x16 A2-70 (2 pcs)

### 3.4 Fitting the process turning disc

#### Location of the process turning disc

The process turning disc is located in the front of the wrist housing as shown in the figure.

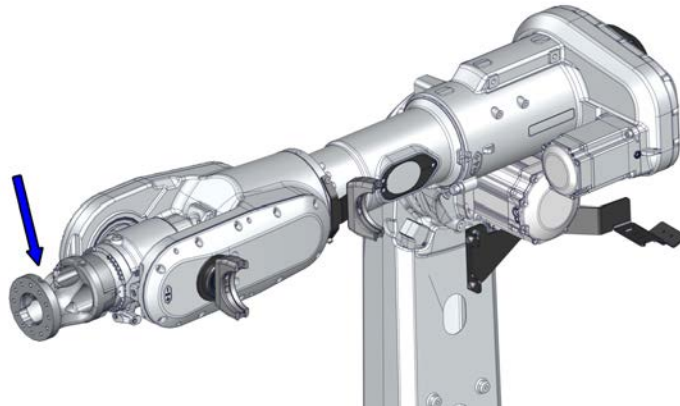

xx2300001042

#### Required spare parts



#### Note

The spare part numbers that are listed in the table can be out of date. See the latest spare parts of the DressPack IRB 6710 via myABB Business Portal, [www.abb.com/myABB](http://www.abb.com/myABB).

Spare part	Article number	Note
Process turning disc	3HAC070389-004	

#### Required service parts

Consumable	Article number	Note
Rust preventive	3HAC034903-001	Mercasol 3110 Waxcoat. Recommended drying time is 24h.

#### Required tools and equipment

Equipment, etc.	Article number	Note
Standard toolkit	-	Content is defined in section <a href="#">Standard toolkit on page 179</a> .

*Continues on next page*

## 3 Installation

### 3.4 Fitting the process turning disc

*Continued*

#### Fitting the process turning disc

Use these procedures to fit the process turning disc.

#### Preparations before fitting the process turning disc

	Action	Note
1	Run the robot to a position most comfortable for fitting the process turning disc. Jog axis 6 to synchronization position.	
2	 <b>DANGER</b> Turn off all: <ul style="list-style-type: none"> <li>• electric power supply</li> <li>• hydraulic pressure supply</li> <li>• air pressure supply</li> </ul> to the robot, before entering the safeguarded space.	
3	Remove the standard turning disc, if installed.	See the product manual for the robot.

#### Fitting the process turning disc

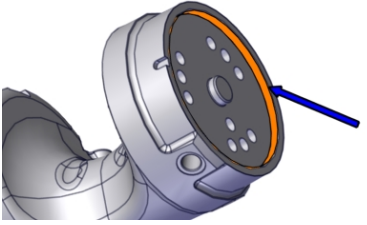
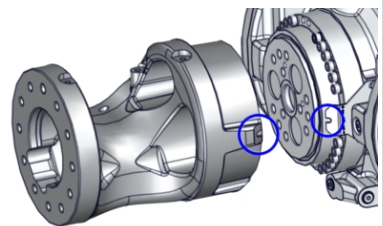
	Action	Note
1	Wipe clean the contact surfaces.	
2	<i>Protection type Foundry Plus:</i> Apply rust preventive to the surface shown in the figure.	Rust preventive: 3HAC034903-001 ( Mercasol 3110 Waxcoat. Recommended drying time is 24h.)  xx2100002692
3	Fit the process turning disc to the wrist. Orient the disc according to the synchronization marks.	 xx2300001044

*Continues on next page*

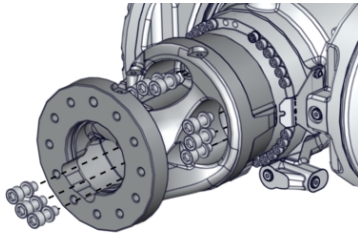
	Action	Note
4	Secure the turning disc with its attachment screws and washers.	<p>Tightening torque: standard torque 70 Nm (<a href="#">Screw joints on page 175</a>)..</p>  <p>xx2300001043</p> <p>Hex socket head cap screw: M10x25 12.9 Gleitmo 603+Geomet 500</p> <p>Washer: 3HAB4233-1</p> <p>9 pcs</p>

#### Concluding procedure

	Action	Note
1	 <p><b>DANGER</b></p> <p>Make sure all safety requirements are met when performing the first test run. See <a href="#">Test run after installation, maintenance, or repair on page 113</a>.</p>	

## 3 Installation

---

### 3.5.1.1 Fitting the lower arm MH cable package

## 3.5 Fitting DressPack cable packages

### 3.5.1 DressPack cable packages axis 1-3

#### 3.5.1.1 Fitting the lower arm MH cable package

---

##### Location of the cable package

The location of the lower arm MH cable package is shown in the figure.



xx2300001074

---

##### Required spare parts



##### Note

The spare part numbers that are listed in the table can be out of date. See the latest spare parts of the DressPack IRB 6710 via myABB Business Portal, [www.abb.com/myABB](http://www.abb.com/myABB).

*Continues on next page*

Spare part	Article number	Note
Harness lower arm MH Paracom	3HAC083476-001	Parallel. All attachments except velcro straps included.
Harness lower arm MH Paramulti	3HAC083482-001	EtherNet. All attachments except velcro straps included.

#### Required service parts



Consumable	Article number	Note
Locking liquid	-	Loctite 2400 (or equivalent Loctite 243)
Velcro strap	3HAC12625-1	5 pcs

#### Required tools and equipment

Equipment, etc.	Article number	Note
M12 dynamometric screw-driver SW15	09 99 000 0646 (article number at Harting Technology Group)	Used to tighten M12 Ethernet connectors.
Standard toolkit	-	Content is defined in section <a href="#">Standard toolkit on page 179</a> .

#### Fitting the lower arm MH cable package

Use this procedure to fit the cable package.



	Action	Note
1	 <b>DANGER</b> Turn off all: <ul style="list-style-type: none"> <li>• electric power supply</li> <li>• hydraulic pressure supply</li> <li>• air pressure supply</li> </ul> to the robot, before entering the safeguarded space.	
2	 <b>CAUTION</b> The cable package is sensitive to mechanical damage. Handle it with care in order to avoid damaging the cabling or the connectors.	

*Continues on next page*

### 3 Installation

#### 3.5.1.1 Fitting the lower arm MH cable package

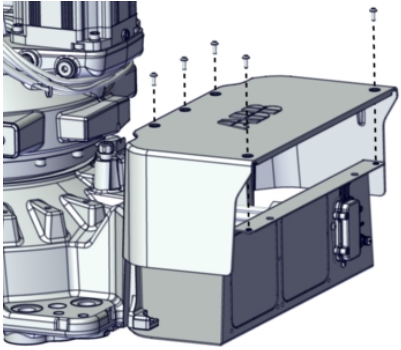
Continued

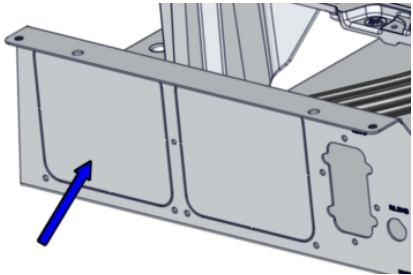
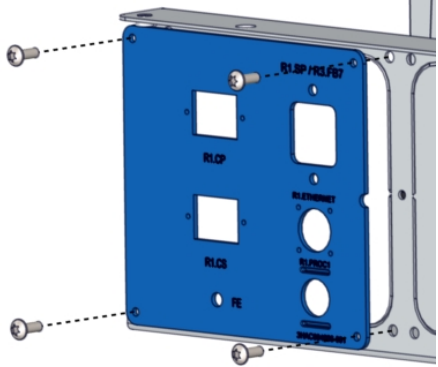
	Action	Note
3	Remove the rear cover plate.	 xx2100000981
4	Remove the part of the back plate where the customer plate is supposed to be fitted. Hit the removable part with a plastic mallet or similar without damaging other parts of the back plate.   <b>Note</b> Only needed when the DressPack cable package is fitted for the first time.	 xx2300001099
5	Fit the customer plate.	 xx2300001075 Torx pan head screw: M6x16 A4-80 (4 pcs)

Continues on next page



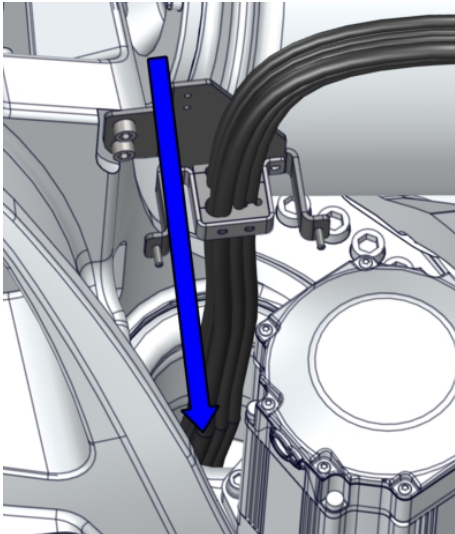
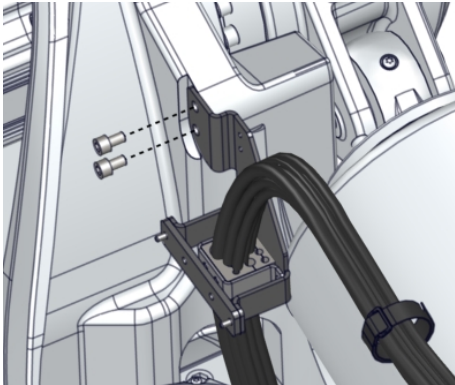
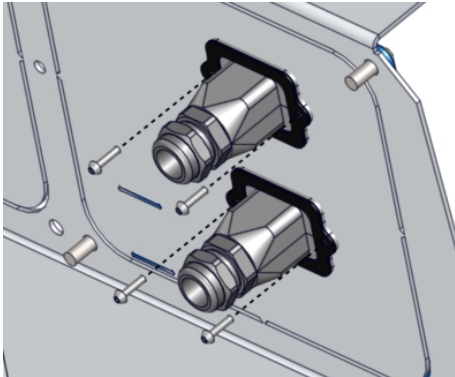

	Action	Note
6	<p>Run the cables down through the center hole of gearbox axis 1, in the following order:</p> <ul style="list-style-type: none"> <li>• Signal cables</li> <li>• Check that the signal cables do not end up between the motor cables</li> <li>• Check that cables do not cross each other.</li> </ul>	 <p>xx2300001079</p>
7	<p>Fit the cable package bracket to the frame with the attachment screws. Use locking liquid.</p>	<p>Locking liquid: Loctite 2400 (or equivalent Loctite 243)</p>  <p>xx2300001086</p> <p>Hex socket head cap screw: M10x16 stainless steel A2-70 (2 pcs)</p>
8	<p>Fit and secure the R1.CP and R1.CS connectors to the customer plate.</p>	 <p>xx2300001077</p> <p>Torx pan head screw: M3x12 Stainless steel A2-70 (2 pcs/connector)</p>

*Continues on next page*

### 3 Installation

#### 3.5.1.1 Fitting the lower arm MH cable package

Continued

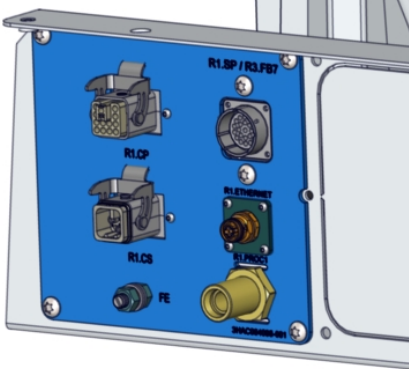
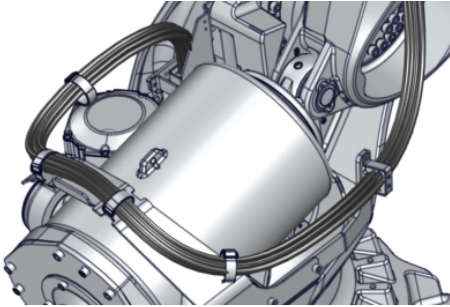
	Action	Note
9	<p>Connect the rest of the cable connectors to the customer plate.</p> <p> <b>CAUTION</b></p> <p>Do not tighten the brass couplings for water and air with excessive force.</p> <p> <b>CAUTION</b></p> <p>If the M12 Ethernet connector is not tightened correctly, there is a risk that the connector can loosen and the cable shield gets disconnected, which will require retightening with the correct torque tools.</p> <p>For secure connection, always tighten at the knurled screw with correct torque and by using proper torque tool, e.g. M12 dynamometric screwdriver SW15 (09 99 000 0646 (article number at Harting Technology Group)).</p>	<p>Tightening torque:</p> <ul style="list-style-type: none"> <li>• Brass coupling 1/2": 31 Nm.</li> <li>• Stainless steel coupling 1/2": 49 Nm.</li> <li>• Brass coupling 3/8": 17 Nm.</li> <li>• Mixed metals: Use the lower tightening torque value of the two metals.</li> </ul> <p>Always apply Molykote P1900 to stainless steel couplings and apply if needed for couplings of mixed metals or brass.</p> <p>Tightening torque, Ethernet M12: 0.6 Nm.</p> <p>Re-check all cables and hoses for straining or twisting.</p> <p>Reroute if necessary!</p>  <p>xx2300001081</p>
10	<p>Route the cables over the balancing device as shown in the figure.</p>	 <p>xx2300001082</p>

Continues on next page

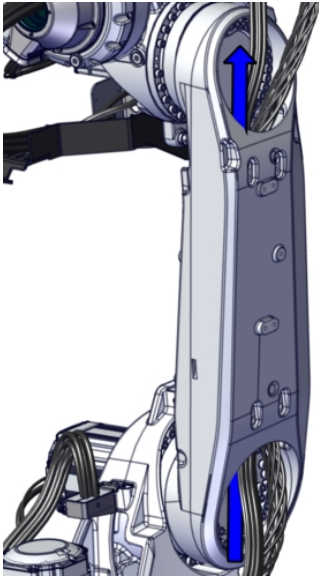
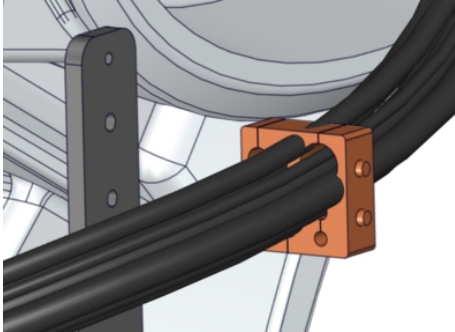
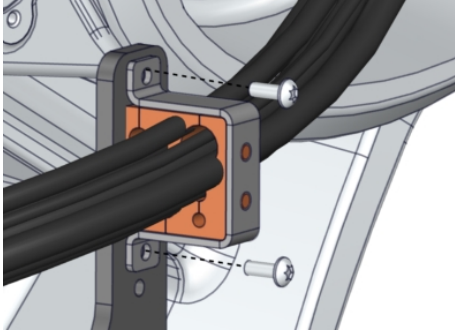
	Action	Note
11	Push the cable package through the inside of the lower arm.	 <p>xx2100002699</p>
12	Find the yellow marking on the cable package, at the side bracket mounting location, and fit the rubber clamp at the marking.	 <p>xx2300001234</p>
13	Fit the cable package rubber clamp to the side bracket arm with the metal clamp and attachment screws.	<p>Locking liquid: Loctite 2400 (or equivalent Loctite 243)</p>  <p>xx2300001235</p> <p>Torx pan head screw: M6x16 A4-80 (2 pcs)</p>

*Continues on next page*

### 3 Installation

#### 3.5.1.1 Fitting the lower arm MH cable package

*Continued*

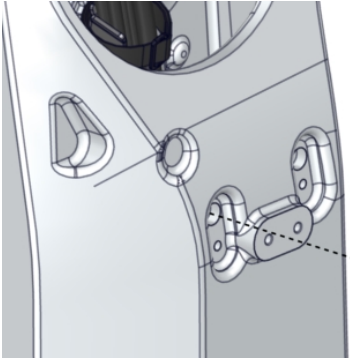
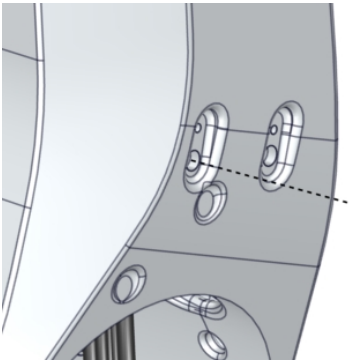
	Action	Note
14	<p>Fit the upper and lower bracket on the inside of the lower arm with attachment screws.</p> <p>Use locking liquid.</p> <p>The DressPack cables between the upper and lower bracket may not be twisted more than 1/2 turn.</p>	<p>Locking liquid: Loctite 2400 (or equivalent Loctite 243)</p>  <p>xx2300001088</p>  <p>xx2300001089</p> <p>Torx pan head screw: M6x16 A4-80 (2 pcs)</p>

*Continues on next page*

#### 3.5.1.1 Fitting the lower arm MH cable package Continued

	Action	Note
15	<p>Fit the cable package bracket to the arm house with the attachment screws.</p> <p>Twist the dress pack cables between the upper and lower arm according to the picture.</p>  <p>xx1900001684</p>	<p>Locking liquid: Loctite 2400 (or equivalent Loctite 243)</p>  <p>xx2300001090</p> <p>Hex socket head cap screw: M10x16 stainless steel A2-70 (2 pcs)</p>
16	<p>Fit the connection plate to the axis-3 mounting plate.</p>	 <p>xx2300001091</p> <p>Hex socket head cap screw: M10x25 A2-70 (2 pcs)</p>

*Continues on next page*

### 3 Installation

#### 3.5.1.1 Fitting the lower arm MH cable package

Continued

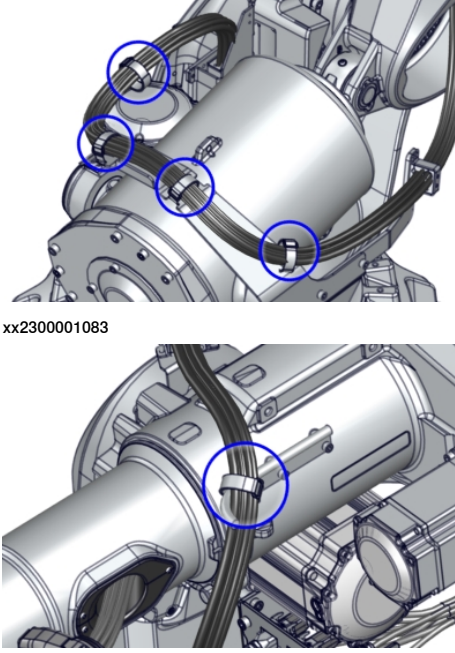
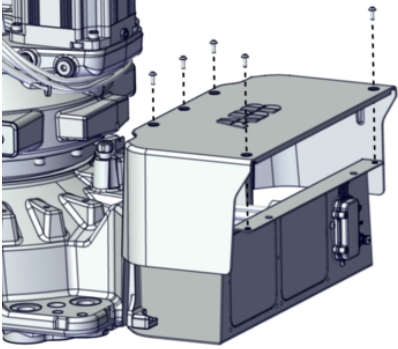
	Action	Note
17	Secure the cable package with velcro straps as shown in the figure.	<p data-bbox="949 315 1086 342">Velcro strap</p>  <p data-bbox="949 674 1054 689">xx2300001083</p> <p data-bbox="949 1014 1054 1030">xx2300001084</p>
18	Refit the rear cover plate.	 <p data-bbox="949 1429 1054 1444">xx2100000981</p> <p data-bbox="949 1458 1406 1485">Torx pan head screw: M6x16 A4-80 (5 pcs)</p>



### 3.5.1.2 Fitting the lower arm SW cable package

#### Location of the cable package

The location of the lower arm SW cable package is shown in the figure.

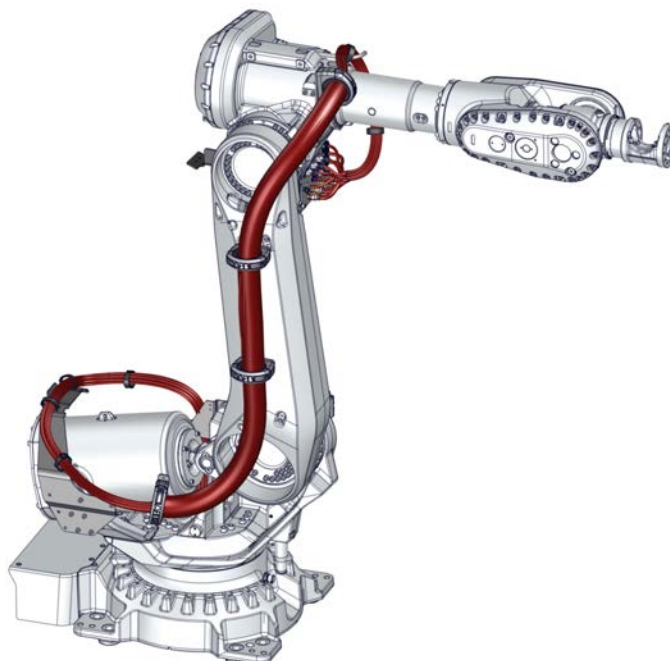

xx2300001045

#### Required spare parts



#### Note

The spare part numbers that are listed in the table can be out of date. See the latest spare parts of the DressPack IRB 6710 via myABB Business Portal, [www.abb.com/myABB](http://www.abb.com/myABB).

Spare part	Article number	Note
Harness lower arm SW Paracom Servo	3HAC086512-001	Parallel-Servo. All attachments except velcro straps included.
Harness lower arm SW Paramulti Servo	3HAC086514-001	EtherNet-Servo. All attachments except velcro straps included.

#### Required service parts

Consumable	Article number	Note
Locking liquid	-	Loctite 2400 (or equivalent Loctite 243)
Velcro strap	3HAC12625-1	6 pcs
Cable ties	-	

*Continues on next page*

## 3 Installation

### 3.5.1.2 Fitting the lower arm SW cable package

*Continued*



#### Required tools and equipment

Equipment, etc.	Article number	Note
M12 dynamometric screwdriver SW15	09 99 000 0646 (article number at Harting Technology Group)	Used to tighten M12 Ethernet connectors.
Standard toolkit	-	Content is defined in section <a href="#">Standard toolkit on page 179</a> .

#### Fitting the lower arm SW cable package

Use this procedure to fit the cable package.

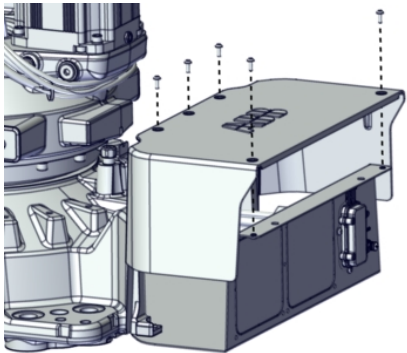

#### Preparations

	Action	Note
1	Move the robot to a comfortable working position.	
2	 <b>DANGER</b> Turn off all: <ul style="list-style-type: none"> <li>• electric power supply</li> <li>• hydraulic pressure supply</li> <li>• air pressure supply</li> </ul> to the robot, before entering the safeguarded space.	
3	 <b>CAUTION</b> The cable package is sensitive to mechanical damage. Handle it with care in order to avoid damaging the cabling or the connectors.	
4	Remove the rear cover plate.	 <p>xx2100000981</p>

*Continues on next page*

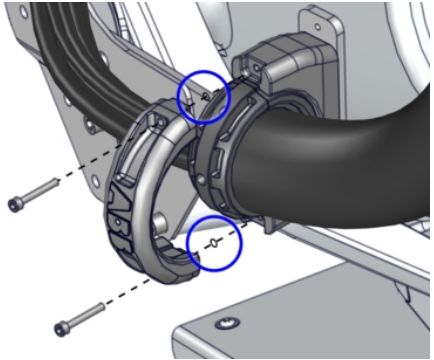
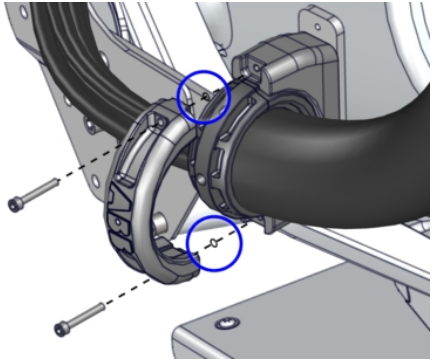

#### Fitting in base and frame

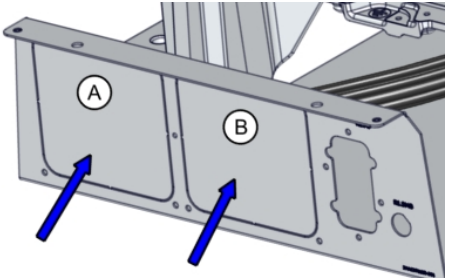
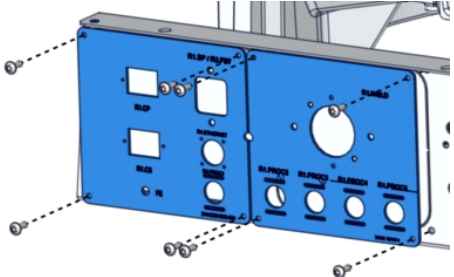
	Action	Note
1 2	<p>1 Place the cable package at the ball joint housing at the side bracket.</p> <p>2 Secure with the upper part of the ball joint housing and screws.</p> <p> <b>Note</b></p> <p>Be careful not to loose the small o-ring on the attachment screw. It keeps the screw from falling off the housing when removed.</p>	 <p>xx2300001046</p> <p>Hex socket head cap screw: M6x40 Steel 8.8-A2F (2 pcs)</p>
3	<p>3 Remove the part of the back plate where the customer and process plates are supposed to be fitted. Hit the removable part with a plastic mallet or similar without damaging other parts of the back plate.</p> <p> <b>Note</b></p> <p>Only needed when the DressPack cable package is fitted for the first time.</p>	 <p>xx2300001100</p> <p>A Customer plate location B Process plate location</p>
4	<p>4 Fit the customer plate and process plate.</p>	 <p>xx2300001085</p> <p>Torx pan head screw: M6x16 A4-80 (9 pcs)</p>

Continues on next page

### 3 Installation

#### 3.5.1.2 Fitting the lower arm SW cable package

Continued

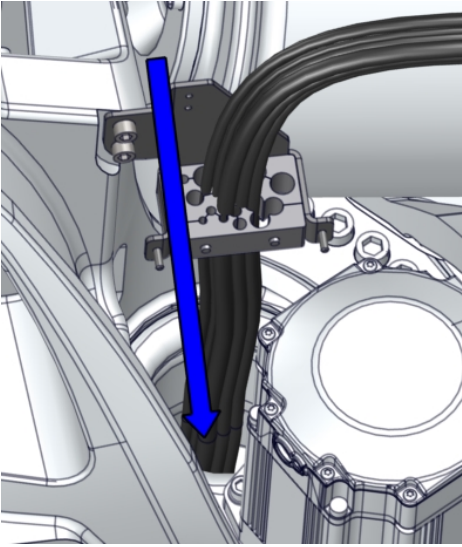
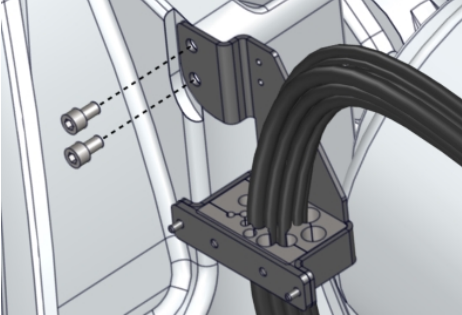
	Action	Note
5	<p>Run the cables down through the center hole of gearbox axis 1, in the following order:</p> <ul style="list-style-type: none"><li>• Harting connector</li><li>• Weld connector</li><li>• Hoses and remaining cables</li></ul> <p> <b>Note</b></p> <p>Make sure that cables and hoses are not twisted through the hole.</p>	 <p>xx2300001080</p>
6	<p>Fit the cable package bracket to the frame with the attachment screws.</p> <p>Use locking liquid.</p>	<p>Locking liquid: Loctite 2400 (or equivalent Loctite 243)</p>  <p>xx2300001094</p> <p>Hex socket head cap screw: M10x16 stainless steel A2-70 (2 pcs)</p>
7	<p>Connect the F2.FB7 connector to the electronic box and secure the cable to the motor cabling with a cable tie.</p>	<p>Cable ties</p>

Continues on next page

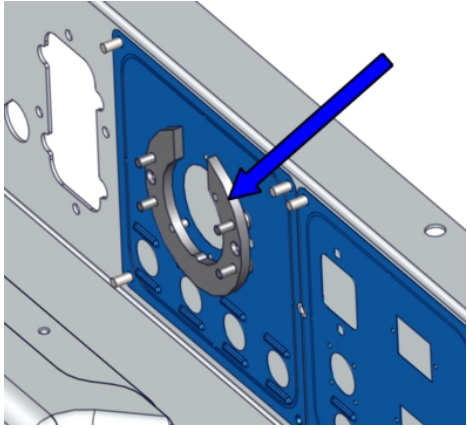
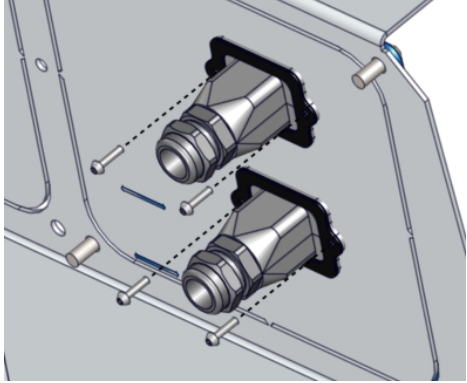

	Action	Note
8	Fit the weld connector bracket.	 <p>xx2300001092</p> <p>Screw dimension:</p> <ul style="list-style-type: none"> <li>• M6x25 A2-70 (2 pcs)</li> </ul>
9	Fit and secure the R1.CP and R1.CS connectors to the customer plate.	 <p>xx2300001077</p> <p>Torx pan head screw: M3x12 Stainless steel A2-70 (2 pcs/connector)</p>

*Continues on next page*

### 3 Installation

#### 3.5.1.2 Fitting the lower arm SW cable package

Continued

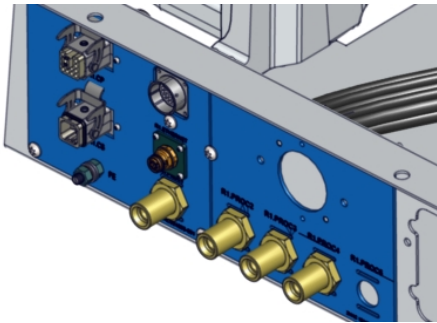
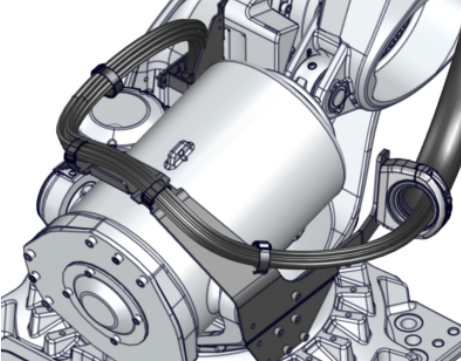
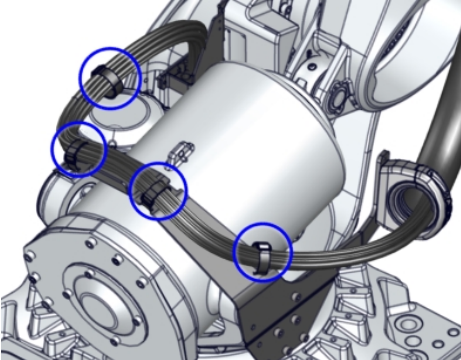

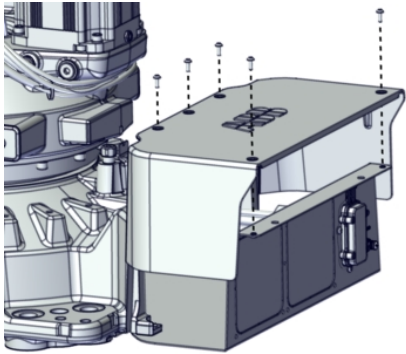

	Action	Note
10	<p>Connect the rest of the cable and hose connectors to the customer plate and process plate.</p> <p><b>Only for Paramulti DressPack:</b> Also connect functional ground.</p> <p> <b>CAUTION</b></p> <p>Do not tighten the brass couplings for water and air with excessive force.</p> <p> <b>CAUTION</b></p> <p>If the M12 Ethernet connector is not tightened correctly, there is a risk that the connector can loosen and the cable shield gets disconnected, which will require retightening with the correct torque tools.</p> <p>For secure connection, always tighten at the knurled screw with correct torque and by using proper torque tool, e.g. M12 dynamometric screwdriver SW15 (09 99 000 0646 (article number at Harting Technology Group)).</p>	<p>Tightening torque:</p> <ul style="list-style-type: none"> <li>• Brass coupling 1/2": 31 Nm.</li> <li>• Stainless steel coupling 1/2": 49 Nm.</li> <li>• Brass coupling 3/8": 17 Nm.</li> <li>• Mixed metals: Use the lower tightening torque value of the two metals.</li> </ul> <p>Always apply Molykote P1900 to stainless steel couplings and apply if needed for couplings of mixed metals or brass.</p> <p>Tightening torque, Ethernet M12: 0.6 Nm.</p>  <p>xx2300001093</p> <p>Recheck all cables and hoses for straining or twisting.</p> <p>Reroute if necessary!</p>
11	<p>Route the cables over the balancing device as shown in the figure.</p>	 <p>xx2300001207</p>
12	<p>Secure the cable package with velcro straps as shown in the figure.</p>	<p>Velcro strap</p>  <p>xx2300001095</p>

Continues on next page

#### 3.5.1.2 Fitting the lower arm SW cable package Continued

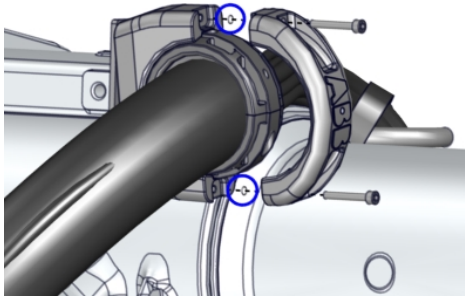
Action	Note
13 Refit the rear cover plate.	 <p>xx210000981</p> <p>Torx pan head screw: M6x16 A4-80 (5 pcs)</p>

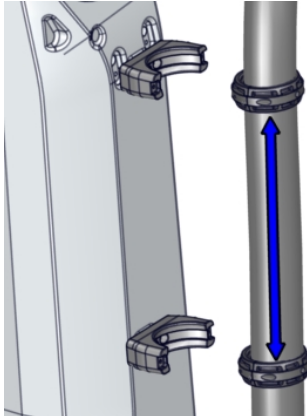
#### Fitting on lower and upper arms

Action	Note
1 Place the cable package at the ball joint housing on top of the upper arm.	 <p>xx2300001101</p> <p>Hex socket head cap screw: M6x40 Steel 8.8-A2F (2 pcs)</p>
2 Secure with the upper part of the ball joint housing and screws.	
<p> <b>Note</b></p> <p>Be careful not to loose the small o-ring on the attachment screw. It keeps the screw from falling off the housing when removed.</p>	 <p>xx2300001102</p>
<p> <b>CAUTION</b></p> <p>Do not change the position of the two clamp inserts on the protection hose, being fitted in the ball joint housings on the lower arm! If the position is changed it will alter the bending movement of the protection hose, when both the upper and lower arms are moved.</p> <p>A change of position of the two clamp inserts may result in serious damage to the cable package!</p>	

Continues on next page

### 3 Installation

#### 3.5.1.2 Fitting the lower arm SW cable package

Continued

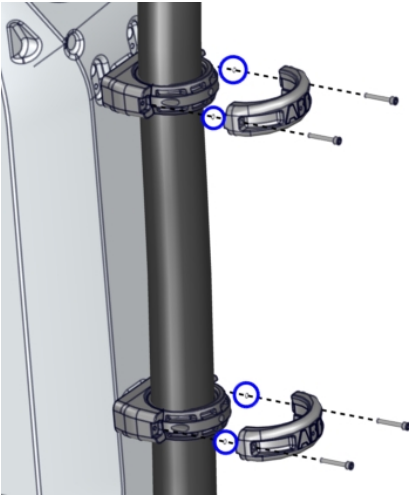
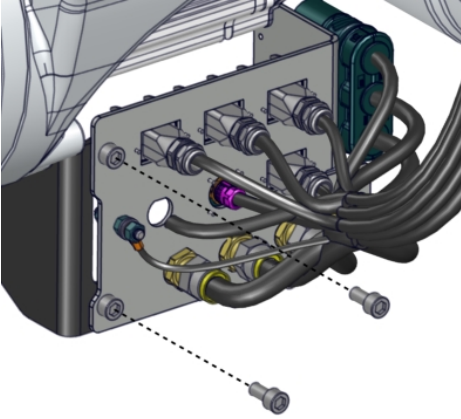
	Action	Note
4	<p>Place the cable package at the ball joint housings on the lower arm.</p> <p> <b>Note</b></p> <p>Be careful not to loose the small o-ring on the attachment screw. It keeps the screw from falling off the housing when removed.</p>	 <p>xx2300001103</p> <p>Hex socket head cap screw: M6x40 Steel 8.8-A2F (2 pcs/housing)</p>
5	<p>Fit the connection plate to the axis-3 mounting plate.</p>	 <p>xx2300001104</p> <p>Hex socket head cap screw: M10x25 A2-70 (2 pcs)</p>

Continues on next page

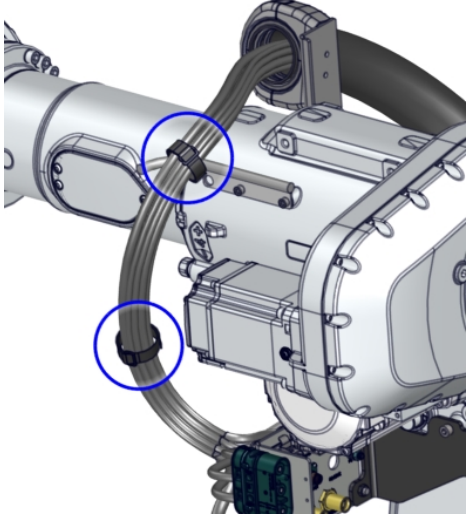
	Action	Note
6	Secure the cable package with velcro straps as shown in the figure.	 <p data-bbox="970 846 1082 869">xx2300001105</p>



## 3 Installation

### 3.5.2.1 Fitting the upper arm MH3 cable package

## 3.5.2 DressPack cable packages axis 3-6

### 3.5.2.1 Fitting the upper arm MH3 cable package

#### Location of cable package

The location of the upper arm MH3 cable package is shown in the figure below.

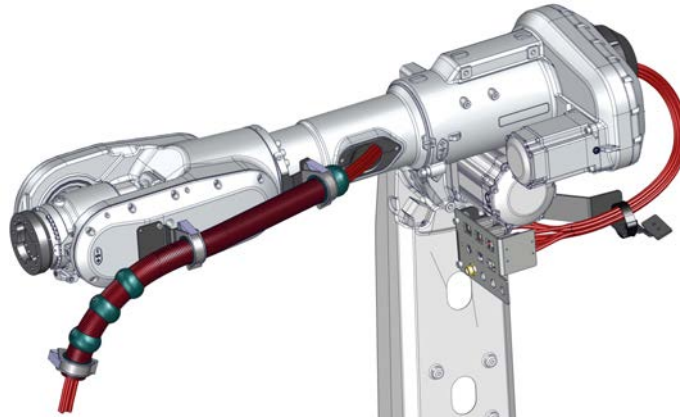

xx2300001106

#### Required spare parts



#### Note

The spare part numbers that are listed in the table can be out of date. See the latest spare parts of the DressPack IRB 6710 via myABB Business Portal, [www.abb.com/myABB](http://www.abb.com/myABB).

Spare part	Article number	Note
Harness upper arm MH3 Paracom	IRB 6710-210/2.65: 3HAC083533-001 IRB 6710-200/2.95: 3HAC083534-001	Parallel. All attachments except velcro straps included.
Harness upper arm MH3 Paramulti	IRB 6710-210/2.65: 3HAC083539-001 IRB 6710-200/2.95: 3HAC083540-001	EtherNet. All attachments except velcro straps included.

#### Required service parts

Consumable	Article number	Note
Locking liquid	-	Loctite 2400 (or equivalent Loctite 243)
Cable grease	3HAC14807-1	Optitemp RB2
Velcro strap	3HAC024008-001	

Continues on next page





#### Required tools and equipment

Equipment, etc.	Article number	Note
M12 dynamometric screwdriver SW15	09 99 000 0646 (article number at Harting Technology Group)	Used to tighten M12 Ethernet connectors.
Standard toolkit	-	Content is defined in section <a href="#">Standard toolkit on page 179</a> .

#### Fitting the upper arm MH3 cable package

Use this procedure to fit the upper arm MH3 cable package.

#### Preparations

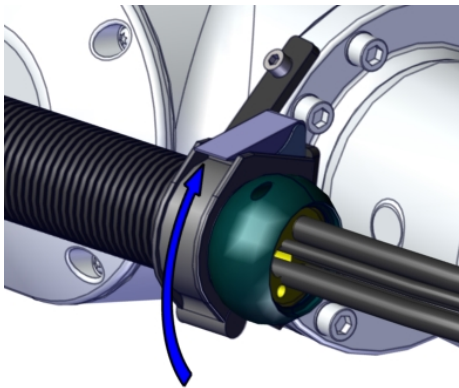
	Action	Note
1	Move the robot to a comfortable working position.	
2	 <b>DANGER</b> Turn off all: <ul style="list-style-type: none"> <li>• electric power supply</li> <li>• hydraulic pressure supply</li> <li>• air pressure supply</li> </ul> to the robot, before entering the safeguarded space.	
3	 <b>CAUTION</b> The cable package is sensitive to mechanical damage. Handle it with care in order to avoid damaging the cabling or the connectors.	
4	Secure the cable package in the ball joint housing on the wrist flange.	 <p>xx2100002759</p>



Continues on next page

### 3 Installation

#### 3.5.2.1 Fitting the upper arm MH3 cable package

*Continued*

##### Fitting the cable package in upper arm tube

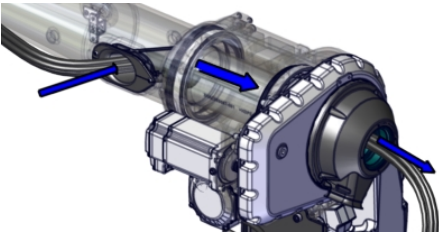
	Action	Note
1	<p>Use caution and push the cable package into the insert, through the tube inside and out in the back of the arm housing.</p> <p> <b>Tip</b></p> <p>This procedure is best done by two persons working together - one pushing cables and hoses into the tube and the other pulling them out at the wrist.</p> <p> <b>Tip</b></p> <p>This is best done following this order:</p> <ol style="list-style-type: none"><li>1 Cables</li><li>2 Weld cables (for spot welding applications)</li></ol>	 <p>xx2100002707</p>

*Continues on next page*

#### 3.5.2.1 Fitting the upper arm MH3 cable package Continued

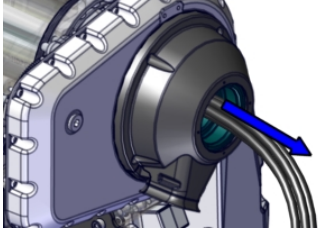
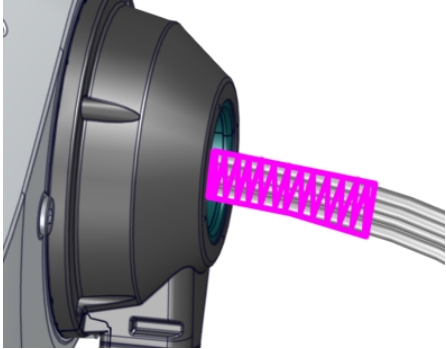
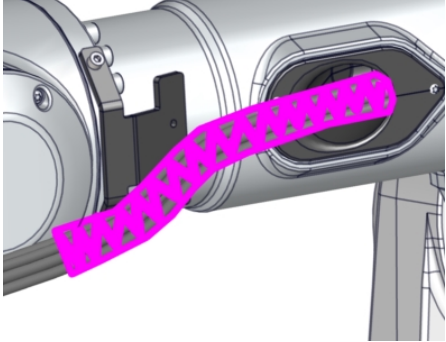
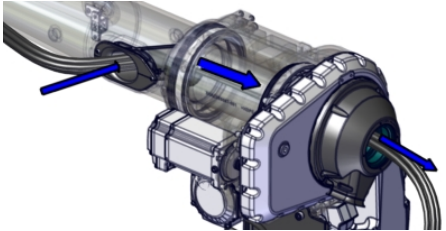
	Action	Note
2	Apply cable grease on the cable package inside the tube according to following procedure:	Cable grease: 3HAC14807-1 (Optitemp RB2)
	Pull the cable package out 10 to 15 centimeters longer than the final mounting position.	 <p>xx2100002708</p>
	Apply grease on the highlighted areas. See figure!	 <p>xx2300001208</p>
	Use caution and push the cable package back into the tube and out through the insert until the area where grease was applied, is visible and able to reach.	
	Apply grease on the highlighted area, so that the cable package inside the tube is covered with cable grease all the way through. See figure!	 <p>xx2300001209</p>
3	Use caution and push the cable package back in through the insert and into its mounting position in the tube.	 <p>xx2100002707</p>

Continues on next page



### 3 Installation

#### 3.5.2.1 Fitting the upper arm MH3 cable package

Continued

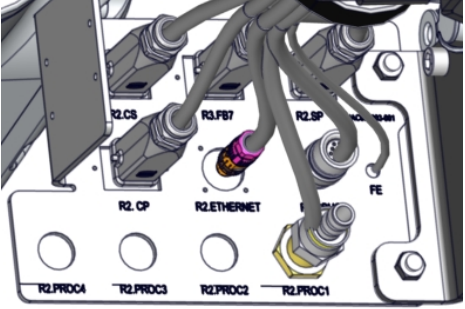
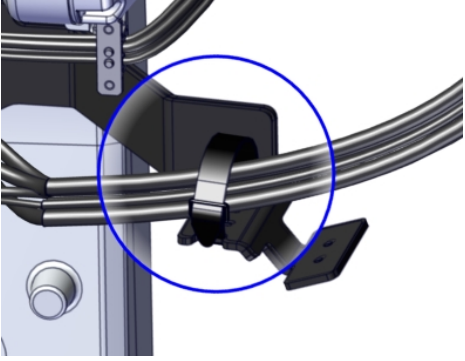

	Action	Note
4	 <b>Note</b> Make sure the cables and hoses are not twisted through the upper arm.	

#### Connecting and fitting on the upper arm

	Action	Note
1	<p>Connect the hose and cable connectors on the connection plate.  <b>Only for DressPack ParaMulti:</b> Also connect functional ground.</p>  <b>Tip</b> For best access to the connectors, start connecting top connectors and continue downwards, ending with Proc 4.  <b>CAUTION</b> If the M12 Ethernet connector is not tightened correctly, there is a risk that the connector can loosen and the cable shield gets disconnected, which will require retightening with the correct torque tools. For secure connection, always tighten at the knurled screw with correct torque and by using proper torque tool, e.g. M12 dynamometric screwdriver SW15 (09 99 000 0646 (article number at Harting Technology Group)).	<p>Tightening torque, Ethernet M12: 0.6 Nm.</p>  <p>xx2300001107</p>
2	<p>Secure the cable package to the mounting plate.</p>	<p>Velcro strap: 3HAC024008-001</p>  <p>xx2100002758</p>

Continues on next page

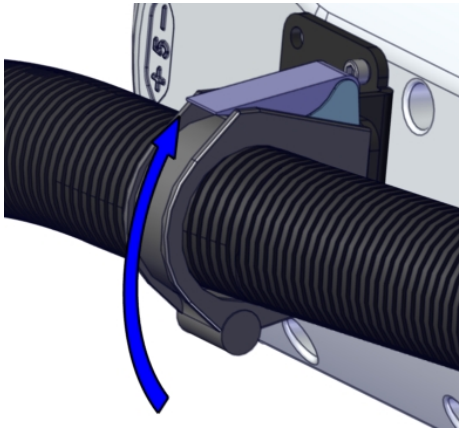
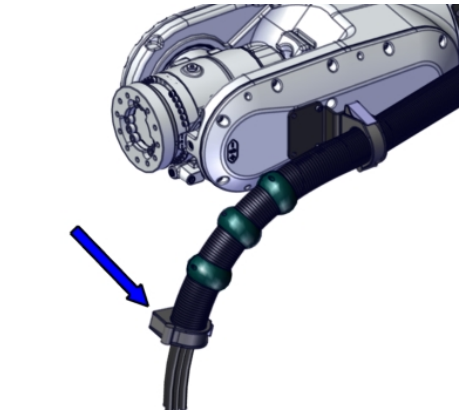
#### Connecting and fitting on the wrist

	Action	Note
1	Secure the cable package in the ball joint housing on the wrist cover.	 <p>xx2100002760</p>
2	Secure the gripping clamp at the front to customer equipment.	 <p>xx2100002761</p>
3	<p> <b>CAUTION</b></p> <p>When the cable package has been fitted on the upper arm, always check potential collision risks between the cable package and the wrist as well as between the cable package and any equipment fitted on the wrist, before restarting the normal production.</p>	
4	Turn on the power and run the present programming at a <i>very slow</i> speed, while checking all movements for collision risk between cable package and wrist.	
5	<p><b>Only valid for EtherNet:</b></p> <p>Connect the functional ground to the customer tool Profinet I/O and or tool changer to increase equipotential bonding.</p>	

Continues on next page

### 3 Installation

---

#### 3.5.2.1 Fitting the upper arm MH3 cable package

*Continued*

	Action	Note
6	 <b>DANGER</b> Make sure all safety requirements are met when performing the first test run. See <a href="#">Test run after installation, maintenance, or repair on page 113</a> .	

### 3.5.2.2 Fitting the LeanID MH / LeanID SW cable package

#### Location of the LeanID MH/SW cable package

The location of the LeanID MH/SW cable package is shown in the figure.

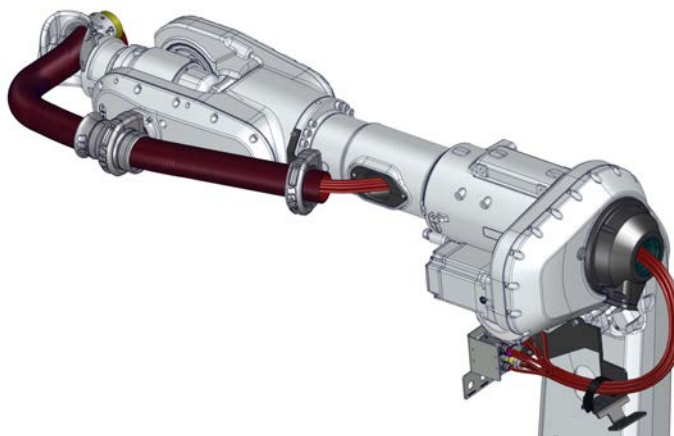

xx2300001108

#### Required spare parts



#### Note

The spare part numbers that are listed in the table can be out of date. See the latest spare parts of the DressPack IRB 6710 via myABB Business Portal, [www.abb.com/myABB](http://www.abb.com/myABB).

Spare part	Article number	Note
Harness upper arm LeanID MH Paracom	IRB 6710-175/2.65 LID: 3HAC083515-001 IRB 6710-175/2.95 LID: 3HAC083516-001	Parallel. All attachments except velcro straps included.
Harness upper arm LeanID MH Paramulti	IRB 6710-175/2.65 LID: 3HAC083521-001 IRB 6710-175/2.95 LID: 3HAC083522-001	EtherNet. All attachments except velcro straps included.
Harness upper arm LeanID SW Paracom Servo	IRB 6710-175/2.65 LID: 3HAC086529-001 IRB 6710-175/2.95 LID: 3HAC086530-001	Parallel-Servo. All attachments except velcro straps included.
Harness upper arm LeanID SW Paramulti Servo	IRB 6710-175/2.65 LID: 3HAC086533-001 IRB 6710-175/2.95 LID: 3HAC086534-001	EtherNet-Servo. All attachments except velcro straps included.

*Continues on next page*

### 3 Installation

#### 3.5.2.2 Fitting the LeanID MH / LeanID SW cable package

Continued

#### Required service parts

Consumable	Article number	Note
Locking liquid	-	Loctite 2400 (or equivalent Loctite 243)
Cable grease	3HAC14807-1	Optitemp RB2
Velcro strap	3HAC024008-001	



#### Required tools and equipment

Equipment, etc.	Article number	Note
M12 dynamometric screwdriver SW15	09 99 000 0646 (article number at Harting Technology Group)	Used to tighten M12 Ethernet connectors.
Standard toolkit	-	Content is defined in section <a href="#">Standard toolkit on page 179</a> .

#### Fitting the LeanID MH/SW cable package

Use these procedures to fit the cable package.

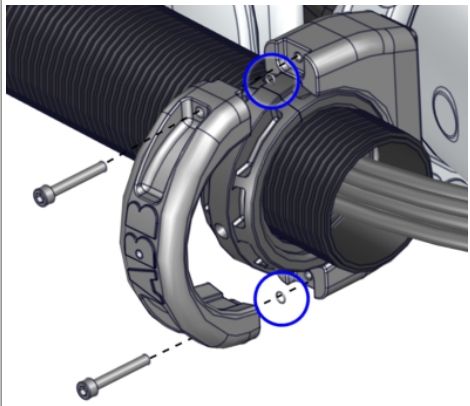

#### Preparations

	Action	Note
1	Move the robot to a comfortable working position.	
2	 <b>DANGER</b> Turn off all: <ul style="list-style-type: none"> <li>• electric power supply</li> <li>• hydraulic pressure supply</li> <li>• air pressure supply</li> </ul> to the robot, before entering the safeguarded space.	
3	Secure the cable package in the ball joint housing on the wrist flange.   <b>Note</b> Be careful not to lose the small o-ring on the attachment screw. It keeps the screw from falling off the housing when removed.	 xx2300001304

Continues on next page

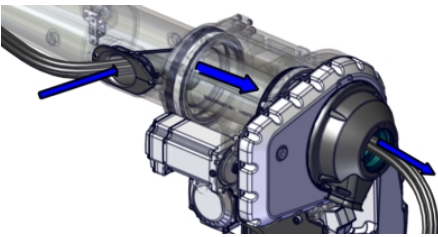

#### Fitting the cable package in upper arm tube

	Action	Note
1	<p>Use caution and push the cable package into the insert, through the tube inside and out in the back of the arm housing.</p> <p> <b>Tip</b></p> <p>This procedure is best done by two persons working together - one pushing cables and hoses into the tube and the other pulling them out at the wrist.</p> <p> <b>Tip</b></p> <p>This is best done following this order:</p> <ol style="list-style-type: none"> <li>1 Cables</li> <li>2 Weld cables (for spot welding applications)</li> </ol>	 <p>xx2100002707</p>

*Continues on next page*

### 3 Installation

#### 3.5.2.2 Fitting the LeanID MH / LeanID SW cable package

Continued

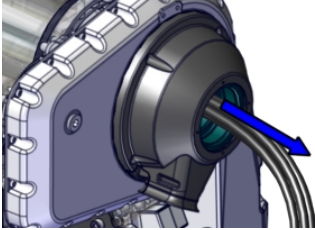
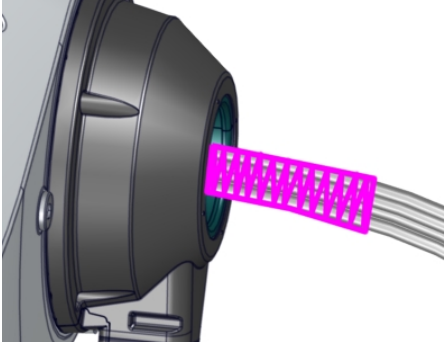
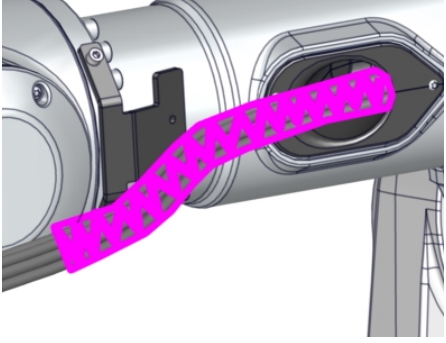
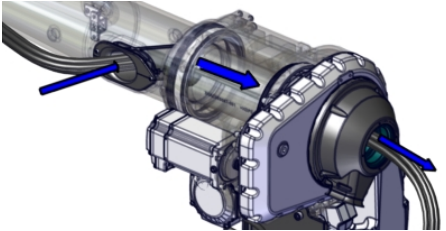

	Action	Note
2	Apply cable grease on the cable package inside the tube according to following procedure:	Cable grease: 3HAC14807-1 (Optitemp RB2)
	Pull the cable package out 10 to 15 centimeters longer than the final mounting position.	 <p>xx2100002708</p>
	Apply grease on the highlighted areas. See figure!	 <p>xx2300001208</p>
	Use caution and push the cable package back into the tube and out through the insert until the area where grease was applied, is visible and able to reach.	
	Apply grease on the highlighted area, so that the cable package inside the tube is covered with cable grease all the way through. See figure!	 <p>xx2300001209</p>
3	Use caution and push the cable package back in through the insert and into its mounting position in the tube.	 <p>xx2100002707</p>

Continues on next page

	Action	Note
4	 <b>Note</b> Make sure the cables and hoses are not twisted through the upper arm.	

#### Fitting the protection hose (protection type Foundry Plus)

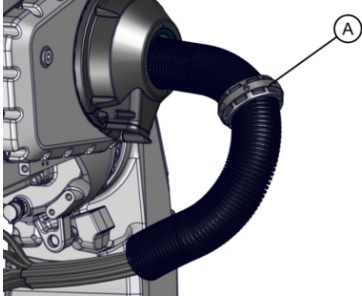
Use this procedure to fit the protection hose for robots with protection type Foundry Plus.

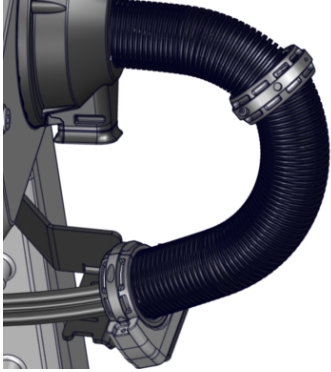
	Action	Note
1	Insert the cable package through the protection hose. For LeanID SW: Use two hoses and attach them with the clamp jaw (A)	 <p>xx2300001245</p> <p><b>A</b> Clamp jaw for cable package LeanID SW</p>
2	Fit the clamp jaw to the end of the hose.	 <p>xx2300001285</p>
3	Lift the cable package up and put the clamp jaw in the ball joint housing.	 <p>xx2300001286</p>

Continues on next page

### 3 Installation

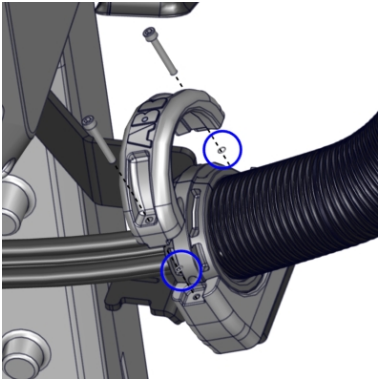

#### 3.5.2.2 Fitting the LeanID MH / LeanID SW cable package

Continued

	Action	Note
4	<p>Secure with the upper part of the ball joint housing and screws.</p> <p> <b>Note</b></p> <p>Be careful not to loose the small o-ring on the attachment screw. It keeps the screw from falling off the housing when removed.</p>	 <p>xx2300001288</p>

#### Weld connectors

Only valid for cable package LeanID SW.

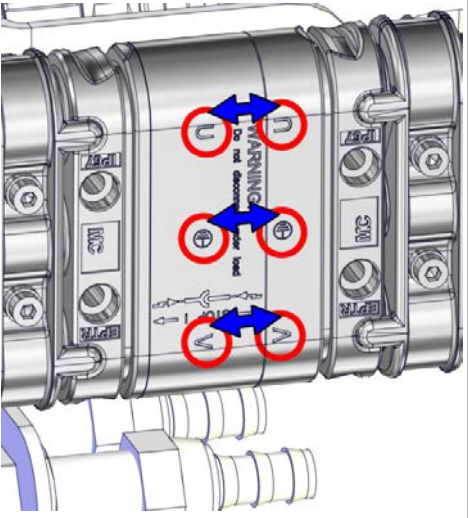
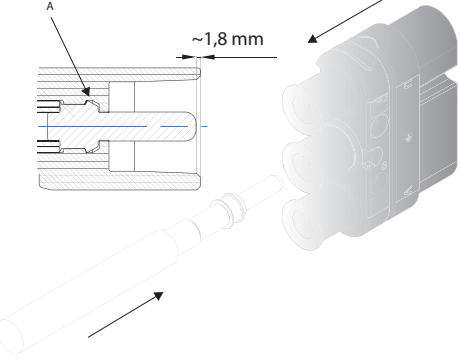
	Action	Note		
1	<p>Press (manually) the cables with the crimped-on contact part into the insulation from the back until it perceptibly engages into place to the detent. See figure!</p> <p> <b>Note</b></p> <p>Make sure the pins are pushed all the way into connector.</p> <p> <b>Note</b></p>  <p>xx1400000216</p>	 <p>xx1300000835</p> <table border="1" data-bbox="948 1301 1410 1346"> <tr> <td data-bbox="948 1301 991 1346">A</td> <td data-bbox="991 1301 1410 1346">Detent</td> </tr> </table>	A	Detent
A	Detent			

Continues on next page

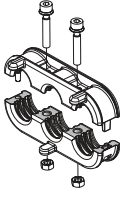
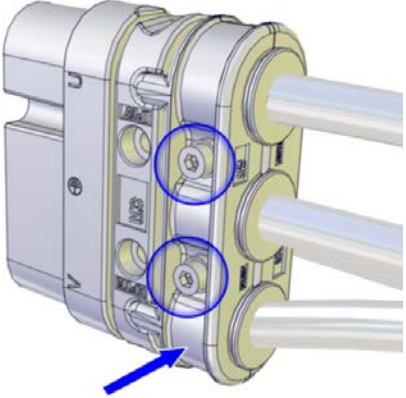
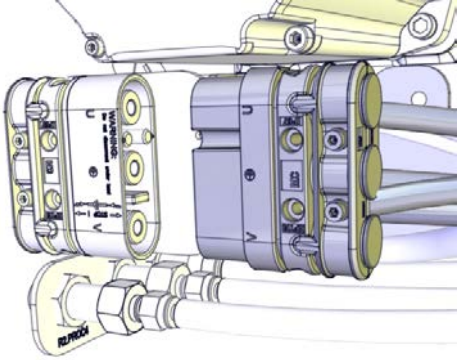
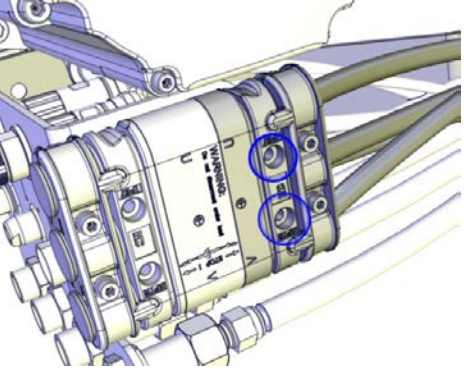
	Action	Note
2	<p>Fit the cable strain relief.</p>  <p>xx1300000836</p>	 <p>xx1200000058</p> <p>Screw dimension:</p> <ul style="list-style-type: none"> <li>• M5x25 8.8-A2F (2 pcs)</li> </ul>
3	<p>Connect the weld cable.</p>	 <p>xx1200000075</p>
4	<p>Fit the weld connector to the mounting plate.</p>	 <p>xx1200000089</p> <p>Screw dimension:</p> <ul style="list-style-type: none"> <li>• M5x40 8.8-A2F (2 pcs)</li> </ul>



*Continues on next page*

### 3 Installation

#### 3.5.2.2 Fitting the LeanID MH / LeanID SW cable package

Continued

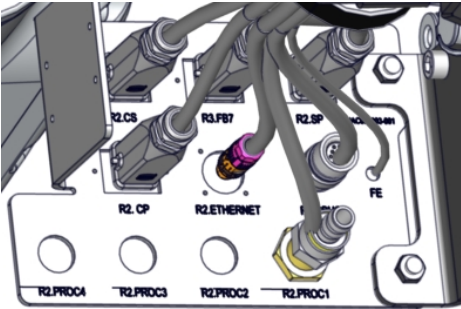
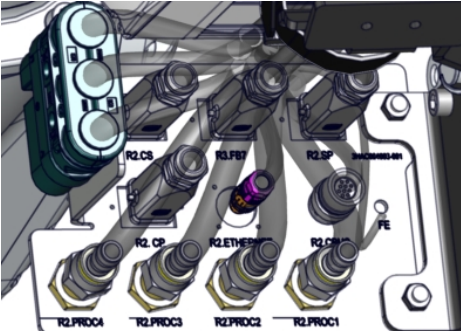
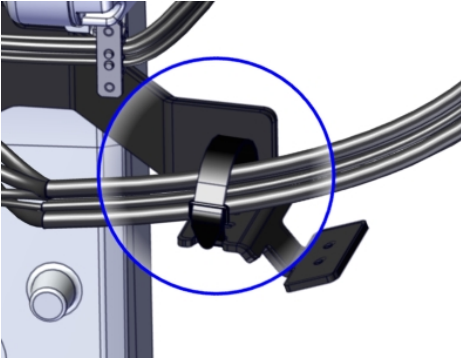

Connecting and securing the cable package to the upper arm

	Action	Note
1	<p>Connect the hose and cable connectors on the connection plate.</p> <p><b>Only valid for DressPack ParaMulti: Also connect functional ground.</b></p> <p> <b>Tip</b></p> <p>For best access to the connectors, start connecting top connectors and continue downwards, ending with Proc 4.</p> <p> <b>CAUTION</b></p> <p>If the M12 Ethernet connector is not tightened correctly, there is a risk that the connector can loosen and the cable shield gets disconnected, which will require retightening with the correct torque tools.</p> <p>For secure connection, always tighten at the knurled screw with correct torque and by using proper torque tool, e.g. M12 dynamometric screwdriver SW15 (09 99 000 0646 (article number at Harting Technology Group)).</p>	<p>Tightening torque, Ethernet M12: 0.6 Nm.</p> <p><b>LeanID MH:</b></p>  <p>xx2300001107</p> <p><b>LeanID SW:</b></p>  <p>xx2300001109</p>
2	<p><b>Valid for protection type Standard:</b></p> <p>Secure the cable package to the mounting plate.</p>	<p>Velcro strap: 3HAC024008-001</p>  <p>xx2100002758</p>

Continues on next page

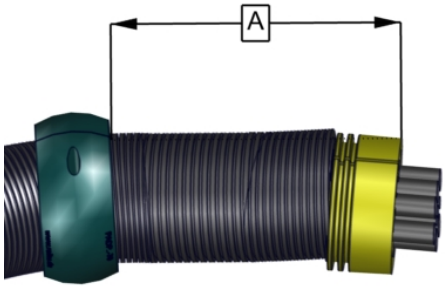
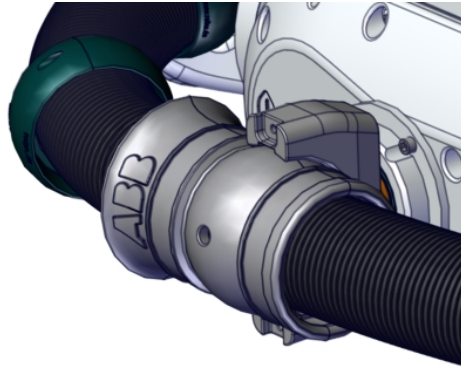

#### Fitting on wrist

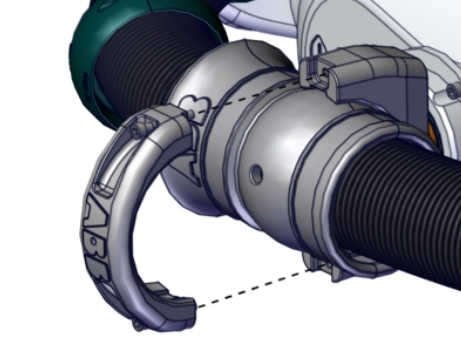
	Action	Note
1	<p>At the end of the cable package, move the protective sleeve so that the distance A between the sleeve and the cable retainer end is 170 mm.</p>	 <p>xx2300001242</p>
2	<p>Place the cable package at the ball joint housing at the wrist bearing. Make sure that the hose reinforcement funnel is fitted correctly, in the direction shown in the figure.</p>	 <p>xx2100002710</p>
3	<p>Secure the cable package in the ball joint housing on the wrist.</p> <p> <b>Note</b></p> <p>Be careful not to loose the small o-ring on the attachment screw. It keeps the screw from falling off the housing when removed.</p>	 <p>xx2100002711</p>

Continues on next page

### 3 Installation

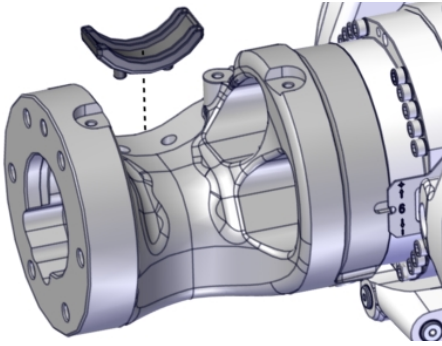
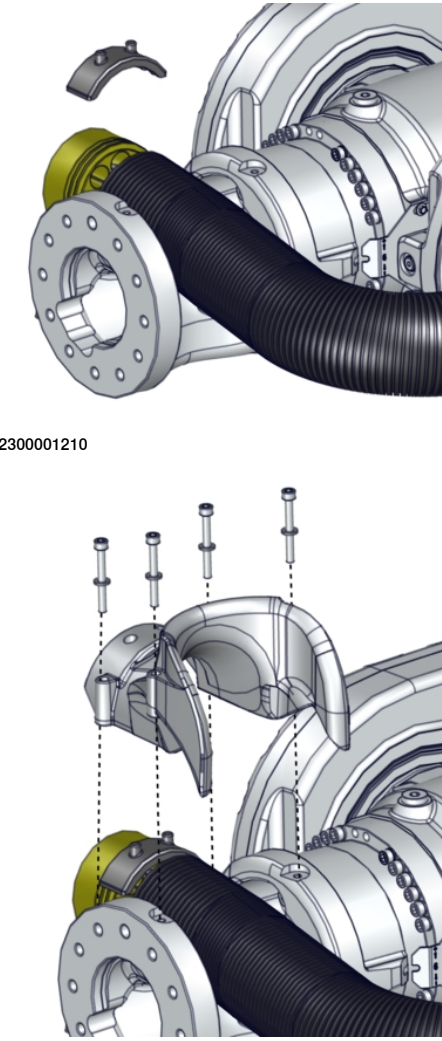

#### 3.5.2.2 Fitting the LeanID MH / LeanID SW cable package

*Continued*

	Action	Note
4	Place the lower bracket of the axis-6 cable support to the process turning disc.	 <p>xx2100002712</p>
5	Place the cable package in the process turning disc and secure it with the upper bracket and the axis-6 cable support.	 <p>xx2300001210</p> <p>xx2300001211</p> <p>Hex socket head cap screw: M6x50 Stainless steel A2-70 (4 pcs) Plain washer: 6.4x12x1.6 steel-A2F (4 pcs)</p>

*Continues on next page*



	Action	Note
6	<p> <b>CAUTION</b></p> <p>When the cable package has been fitted on the upper arm, always check potential collision risks between the cable package and the wrist as well as between the cable package and any equipment fitted on the wrist, before restarting the normal production.</p>	
7	<p>Turn on the power and run the present programming at a <i>very slow</i> speed, while checking all movements for collision risk between cable package and wrist.</p>	
8	<p><b>Only valid for Paramulti:</b></p> <p>Connect the functional ground to the customer tool Profinet I/O and or tool changer to increase equipotential bonding.</p>	
9	<p> <b>DANGER</b></p> <p>Make sure all safety requirements are met when performing the first test run. See <a href="#">Test run after installation, maintenance, or repair on page 113</a>.</p>	

#### Final check of protective sleeve

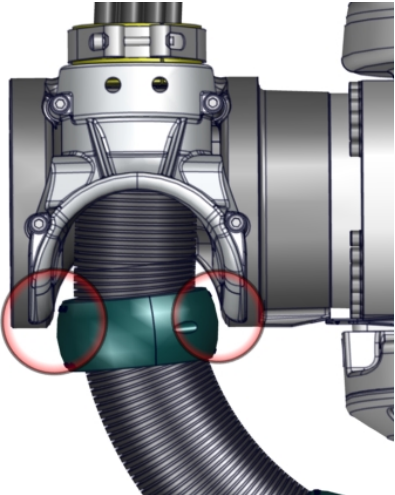
	Action	Note
1	<p>In order to be sure that the protective sleeve still is in the correct position, check its position after some hours running. This is done to prevent the protection hose from wear. See figure!</p>	 <p>xx2300001241</p>
2	<p>If required, adjust the position of the protective sleeve.</p>	

### 3 Installation

#### 3.6 Installation of cabling in MH / SW LID Empty Conduit (option 3326-30 / 3326-50)

#### 3.6 Installation of cabling in MH / SW LID Empty Conduit (option 3326-30 / 3326-50)

##### Location of the empty conduit

The location of the empty conduit is shown in the figure.

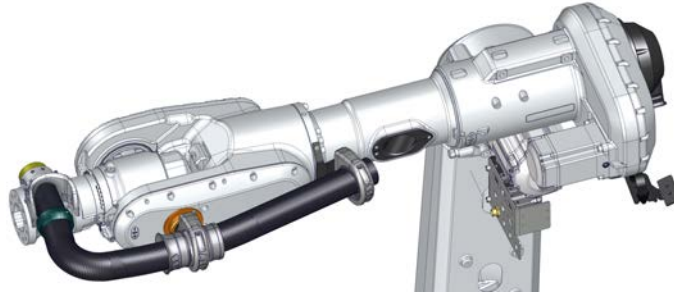

xx2300001314

##### Required cable length

Route the cables through the empty conduit, from the axis-3 mounting plate to the axis-6 cable retainer end, as shown in the figure.

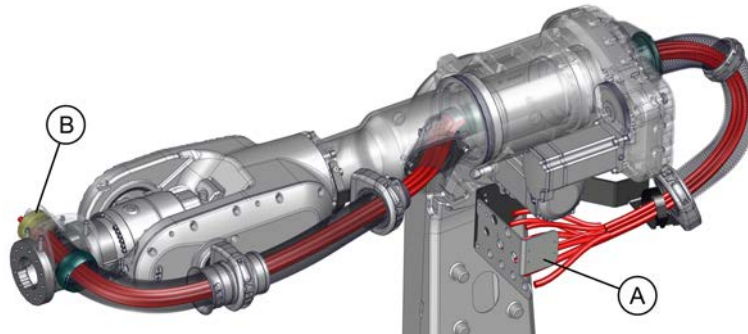

xx2300001313

A	Axis-3 mounting plate
B	Axis-6 cable retainer

Manipulator variant	Required length from axis-3 mounting plate to axis-6 cable retainer	Recommended length from axis-6 cable retainer to customer tool
IRB 6710-175/2.65 LID	3.5 m	1 m
IRB 6710-175/2.95 LID	3.9 m	1 m

*Continues on next page*

#### Specification of the axis-6 cable retainer

The holes in the cable retainer consist of different sizes, as shown in the figure.

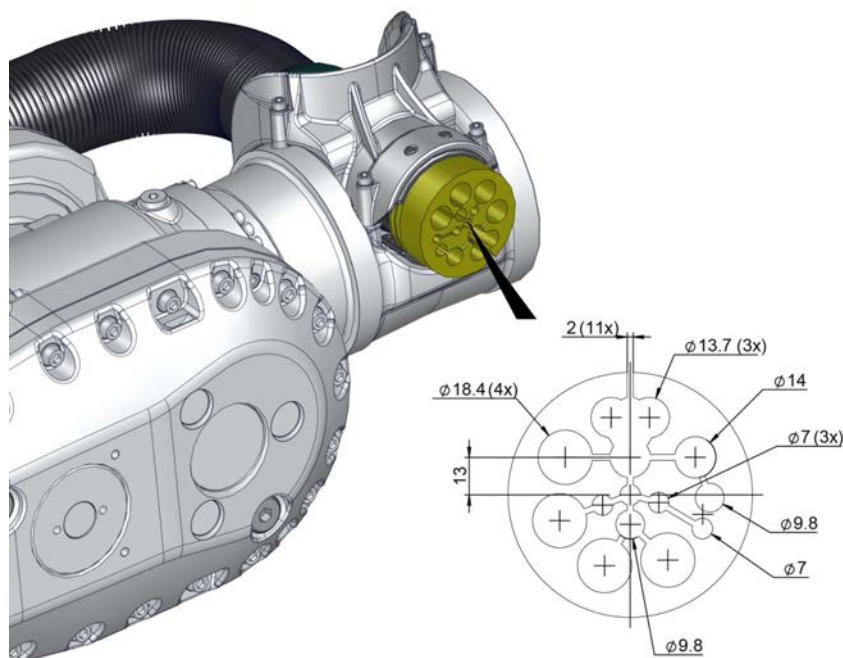

xx2300001316

- At delivery all holes are filled with fillers. Reuse the fillers in the holes that are not used.
- The cable diameter should not be smaller than the hole, for example: a 18.4 mm hole is used for 1/2" media hoses with an outer diameter of 19 mm. If the cable to be used is smaller, use suitable glued shrink hose to build up the diameter.

#### Required spare parts



#### Note

The spare part numbers that are listed in the table can be out of date. See the latest spare parts of the DressPack IRB 6710 via myABB Business Portal, [www.abb.com/myABB](http://www.abb.com/myABB).

Spare part	Article number	Note
Protection hose	3HAC080953-001	Purchased per meter.
Hose reinforcement funnel	3HAC032916-001	Order 2 pcs to get both parts.
Protective sleeve, rotary	3HAC032660-001	
Cable clamp, insert	3HAC042483-001	Order 2 pcs to get both parts.
Cable retainer	3HAC083950-001	

*Continues on next page*

### 3 Installation

#### 3.6 Installation of cabling in MH / SW LID Empty Conduit (option 3326-30 / 3326-50)

Continued

#### Required service parts

Consumable	Article number	Note
Cable grease	3HAC14807-1	Optitemp RB2

#### Required tools and equipment

Equipment, etc.	Article number	Note
Standard toolkit	-	Content is defined in section <a href="#">Standard toolkit on page 179</a> .

#### Installing the cabling into the empty conduit

Use this procedure to install the cabling into the empty conduit.

#### Removing the protection hose

Use this procedure to remove the protection hose from the manipulator.

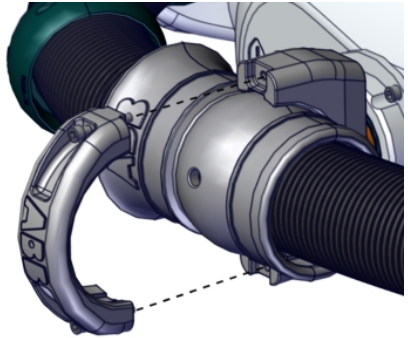
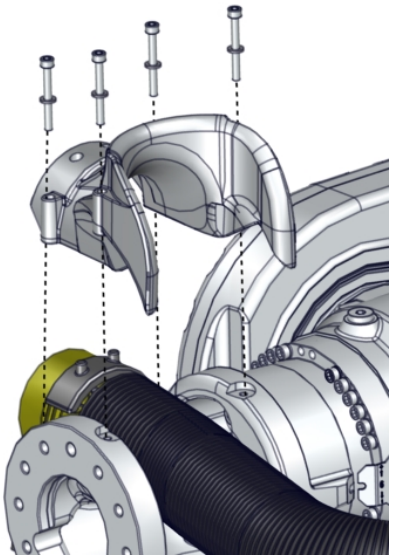
Action	Note
<p>1 Remove the upper part of the ball joint housing on the wrist cover.</p> <p> <b>Note</b></p> <p>Be careful not to lose the small o-ring on the attachment screw. It keeps the screw from falling off the housing when removed.</p>	 <p>xx2100002711</p>
<p>2 Remove the axis 6 cable support.</p>	 <p>xx2300001211</p>



Continues on next page

#### 3.6 Installation of cabling in MH / SW LID Empty Conduit (option 3326-30 / 3326-50)

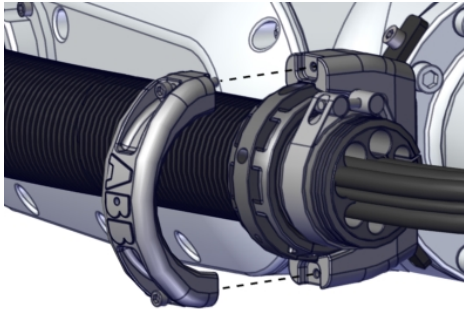
Continued

	Action	Note
3	<p>Remove the upper part of the ball joint housing on the wrist flange.</p> <p> <b>Note</b></p> <p>Be careful not to loose the small o-ring on the attachment screw. It keeps the screw from falling off the housing when removed.</p>	 <p>xx2100002709</p>
4	<p>Remove the empty protection hose from the manipulator and place it on a work-bench.</p>	

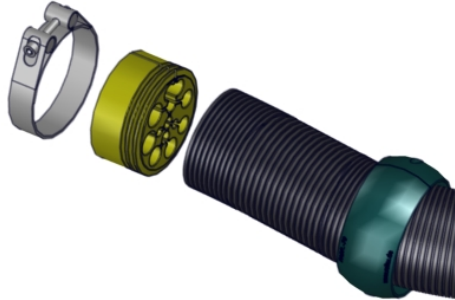
#### Installing the cabling to the protection hose

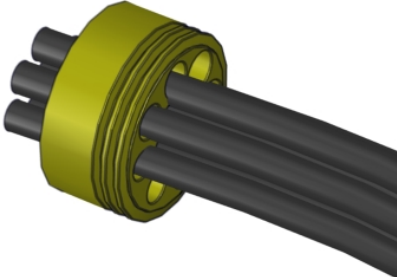

	Action	Note
1	<p>Remove the hose clamp and the cable and hose retainer.</p> <p> <b>CAUTION</b></p> <p>Do not contaminate the cable retainer with cable grease.</p>	 <p>xx2300001315</p>
2	<p>Clean the cables and hoses from any lubrication at the mounting points of the cable retainer.</p> <p>Also clean the retainer, if necessary.</p> <p> <b>CAUTION</b></p> <p>No lubrication is allowed in the cable retainer. Make sure to clean cables, hoses and the cable retainer, if necessary.</p>	
3	<p>Fit the cables to the cable retainer, according to the specifications in <a href="#">Specification of the axis-6 cable retainer on page 95</a>.</p> <p> <b>Note</b></p> <p>The cable diameter should not be smaller than the hole, for example: the 18.4 mm hole is used for 1/2" media hoses with an outer diameter of 19 mm. If the cable to be used is smaller, use suitable glued shrink hose to build up the diameter.</p>	 <p>xx2300001320</p>

Continues on next page

### 3 Installation

#### 3.6 Installation of cabling in MH / SW LID Empty Conduit (option 3326-30 / 3326-50)

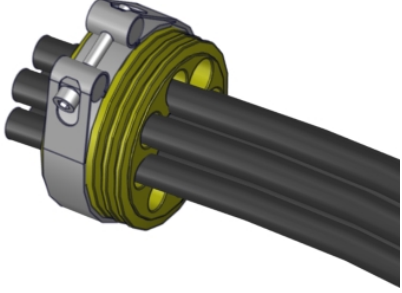
Continued

	Action	Note
4	Fit fillers into the cable retainer holes that are not used.	
5	<p>Fit and tighten the hose clamp to secure the cables from moving during operation. If some of the cables are still movable by hand when the clamp has reached its end position, the cable diameter must be increased.</p> <p> <b>CAUTION</b></p> <p>Pulling the cables with excessive force might cause internal damage to sensitive cables.</p>	 <p>xx2300001321</p>
6	Put some cable grease on cables and hoses on the area where they run through the protection hose and hose reinforcement funnel.	
7	Push the cables into the protection hose. Make sure that cables are not twisted.	 <p>xx2300001322</p>
8	Fit the cable package to the manipulator according to <a href="#">Fitting the LeanID MH / LeanID SW cable package on page 83</a> .	

### 3.7 Inspection, DressPack lower arm

#### General

In order to ensure adequate life of the equipment, it is vital that the cables and hoses are properly installed and operated correctly, with their movement patterns well within the acceptable limits.

This procedure describes how to inspect the DressPack lower arm installation in this regard.

#### Inspecting the process cable package

	Action	Note
1	<p><i>Do not bend</i> any cable or hose excessively!</p>  <b>Note</b> Make sure no cables or hoses are twisted.	Minimum bending radius is approximately 10x the cable or hose diameter.
2	Make sure all cables straps are tight enough to prevent the cable package from moving in any undesired way.	
3	Make sure the cable package is properly connected at the connection plate as well as at the robot base.	
4	Make sure no hoses or cables, or parts thereof, touch any part of the robot structure in a way that may cause wear.	
5	Make sure all cables and hoses move smoothly together during operation and that no part of the cable package moves in a different pattern.	
6	Make sure that cables, hoses or packages do not rub against <i>any sharp corner of something</i> (not just the robot itself)!	
7	Make sure all connection points are well tightened and sealed in order to avoid leaks.	

#### Inspecting the attachments and brackets

	Action	Note
1	Make sure that all cable clamps securing the process cable package and protective hose are tightened correctly.	Tightening torques are specified: <ul style="list-style-type: none"> <li>• For <i>standard tightening torques</i> - See tightening torque table in chapter References.</li> <li>• For <i>non standard tightening torques</i> see chapter <i>Installation</i>.</li> </ul>

## 3 Installation

### 3.8 Inspection, DressPack upper arm

### 3.8 Inspection, DressPack upper arm

#### Introduction

In order to ensure adequate life of the equipment, it is vital that the cables and hoses are properly installed and operated correctly, with their movement patterns well within the acceptable limits.

This section describes how to inspect the DressPack upper arm installation in this regard.

#### General inspection

	Action	Note
1	Inspect all attachments, wear rings and any other hardware securing or guiding the protective hose.	For details, see below!
2	Inspect and make sure all cables and hoses are securely fixed and connected.	For details, see below!
3	Make sure that it is enough space between the <i>process cable support, axis 6</i> and the <i>Protection cover, calibration pin axis 6</i> .	

#### Inspecting the cables and hoses

Use this procedure to inspect cables and hoses, not necessarily in any particular order if not so stated.

	Action	Note
1	Do not bend any cable or hose excessively!	Minimum bending radius is approximately 10x the cable or hose diameter.
2	Make sure no cables or hoses are twisted.	
3	Make sure that all hoses and cables to gun or gripper are long enough to avoid stretching.	
4	Make sure that the protection hose is rotating correctly in the hose reinforcement funnel.	
5	Make sure that the hose reinforcement funnel is tilting correctly in the ball joint housing.	
6	Make sure that cables are clamped with straps in a way that there is no movement at connectors.	Use only wide straps or velcro straps in order not to damage the cables and hoses.
7	Make sure that no hoses or cables, or parts thereof, touch any part of the robot structure in a way that may cause wear.	
8	Make sure that no hoses or cables, or parts thereof, touch any part of the surrounding equipment in a way that may cause wear.	
9	Make sure all cables and hoses move smoothly together during operation.	

*Continues on next page*



**Inspecting the cable packages**

Use this procedure to verify that the cable packages are secured and connected properly, not necessarily in any particular order unless stated.

	Action	Note
1	Recheck all cable clamps that secure the process cable package and protective hose for tightness.	Tightening torques are specified: <ul style="list-style-type: none"> <li>• For <i>standard tightening torques</i> - See tightening torque table in chapter References.</li> <li>• For <i>non standard tightening torques</i> - See Installation chapter.</li> </ul>
2	Make sure all cable straps are tight enough to prevent the cable package from moving in any undesired way. The cable ties should not be too narrow. This may damage the cables/hoses.	
3	When securing cables and hoses with cable ties: <i>never</i> overtighten the ties! This may damage the equipment.	
4	Make sure that the cable package has been properly connected at the connection plate at axis 3, as well as at the tool on the robot turning disc.	
5	Make sure all connection points are well tightened and sealed in order to avoid leaks.	
6	Make sure the weight of the cable package is secured to the tool in order to avoid straining the connectors!	

## 3 Installation

---

### 3.9 Expected lifetime of the integrated DressPack cable package

### 3.9 Expected lifetime of the integrated DressPack cable package

---

#### General

The expected lifetime of the integrated DressPack cable package is dependent of the actual robot cycle. For the robot upper arm (axes 4, 5, and 6) the combination of the robot axes gives influence on lifetime. Below are recommendations for programming given as well as expected lifetime based on long term tests as well as normal spot welding application cycles.

#### Expected life time

If the robot cycle is done according to the recommendations above, a lifetime could be expected for a normal spot welding cycle in two shift production, as shown in the table.

4 years	DressPack cable package LeanID MH / LeanID SW
2 years	DressPack cable package upper arm MH3
More than 6 years	DressPack cable package lower arm MH / SW

#### Recommendations for programming

Robot variants IRB 6710-175/2.65 LID, IRB 6710-175/2.95 LID have working range limitations implemented in the system parameters in RobotWare.

For robot variants IRB 6710-210/2.65, IRB 6710-200/2.95, the movements of axis-5 and axis-6 must be programmed in accordance with not damaging the upper arm MH3 cable package at the wrist, depending on customer configuration.

## 3.10 DressPack adjustments



### 3.10.1 Adjustments of the cable package - upper arm MH3

#### Overview

The procedure below details how to adjust the routing of the upper arm MH3 cable package, in order to avoid reducing its life.

#### Hoses and cables too long around the wrist

Depending on robot version and gripper design, the length of the protection hose and cables may need to be adjusted.

	Action	Note
1	 <b>DANGER</b> Turn off all: <ul style="list-style-type: none"> <li>• electric power supply</li> <li>• hydraulic pressure supply</li> <li>• air pressure supply</li> </ul> to the robot, before entering the safe-guarded space.	
2	 <b>CAUTION</b> The cable package is sensitive to mechanical damage. Handle it with care in order to avoid damaging the cabling or the connectors.	
3	If the protection hose is too long, cut it to the desired length.	
4	If the cables are too long, pull them back out of the protection hose and then put them in a loop. Fit the cables with the enclosed straps on the bracket.	

## 3 Installation

### 3.10.2 Inspection during programming and test-running

#### 3.10.2 Inspection during programming and test-running

##### General

In order to ensure adequate life of the equipment, it is vital that the cables and hoses are properly installed and operated correctly, with their movement patterns well within the acceptable limits.

##### Checking the cable package at the upper arm

This procedure describes how to inspect the DressPack upper arm installation during programming and test-running the complete installation the very first times.

##### Upper arm MH3, LeanID MH, LeanID SW

This instruction describes how to inspect the DressPack installation during programming and test-running the complete installation the very first times.

	Action	Note
1	Inspect the DressPack upper arm installation before programming and test-running.	See <a href="#">Inspection, DressPack upper arm on page 100</a> .
2	Check the operating cycle of the robot, to make sure the movement pattern of the wrist does not cause extensive wear or strain of the cable package.	If required, re-program the robot movement pattern!
3	Make sure the upper arm protective hose <i>does not get flattened</i> during rotating upper arm movements.	Flattening indicates an overstressed hose and <i>increases</i> the risk of damaging the DressPack upper arm.
4	Make sure the process cable package does not rub against the sides of the wrist more than absolutely necessary.	The rubbing may result in the cable getting stuck. When the package is released, the retracting unit may snap back, potentially causing damage to the equipment.
5	If any of the actions recommended above, causes a change of the DressPack installation, it must be reinspected.	See section <a href="#">Inspection, DressPack upper arm on page 100</a> .
6	Make sure that the velcro straps are not too tight. The cables should be able to twist individually. The cable ties shall be tight.	
7	Make sure that no parts of the DressPack are in contact with the surroundings.	

##### Checking the DressPack at the lower arm

This instruction describes how to inspect the DressPack lower arm installation during programming and test-running the complete installation the very first times.

	Action	Note
1	Inspect the DressPack lower arm installation before programming and test-running.	See section <a href="#">Inspection, DressPack lower arm on page 99</a>
2	Check the operating cycle of the robot, to make sure the movement pattern of the robot does not cause extensive wear or straining on the cable package.	If required, re-program the robot movement pattern!

*Continues on next page*

#### 3.10.2 Inspection during programming and test-running

*Continued*

	Action	Note
3	If any of the actions recommended above, causes changes of the DressPack lower arm installation, it must be reinspected.	See section <a href="#">Inspection, DressPack lower arm on page 99</a>

### 3 Installation

#### 3.11.1 DressPack - arm load parameters and LoadId

### 3.11 DressPack arm load parameters

#### 3.11.1 DressPack - arm load parameters and LoadId

##### General

A DressPack is adding load to the robot. If the arm and tool loads are not stated correctly, this will affect the behavior and the wear of the robot.



##### Note

The extra weight of the DressPack products will affect the arm load data and the performance of the robot. The effect differs depending on which type of DressPack product being used.

##### Coordinate system definitions

Coordinate system definitions when defining arm loads.

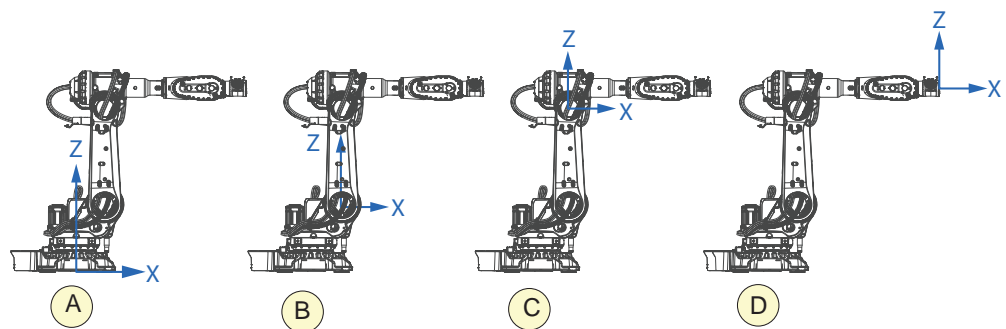

xx2100002716

A	Frame - axis 1
B	Lower arm - axis 2 (Z is in the lower arm direction)
C	Upper arm - axis 3 /axis 4 (X is in the upper arm direction)
D	Wrist - axis 6

##### Arm load parameters for spot welding



##### Note

These values reflect the standard mounting of the Process bracket, pointing straight upwards in the robot calibration position. If the mounting is changed, the X, Y and Z values must be changed correspondingly.

##### Arm load parameters IRB 6710-175/2.65 LID, LeanID SW

These tables show the values for the LeanID SW cable package - spot welding.

6710-175/2.65 LID SW	Mass [kg]	Mass CenterX [m]	Mass CenterY [m]	Mass CenterZ [m]
Frame - axis 1	15.4	-0.15	-0.275	0.362
Lower arm - axis 2	7.6	0.059	-0.464	0.693

*Continues on next page*

6710-175/2.65 LID SW	Mass [kg]	Mass CenterX [m]	Mass CenterY [m]	Mass CenterZ [m]
Upper arm - axis 3	20.6	0.102	0.016	0.061
Upper arm - axis 4	8.5	0.91	0.213	0.202
Wrist - axis 6	4	-0.0805	0	0

#### Arm load parameters IRB 6710-175/2.95 LID, LeanID SW

These tables show the values for the LeanID SW cable package - spot welding.

6710-175/2.95 LID SW	Mass [kg]	Mass CenterX [m]	Mass CenterY [m]	Mass CenterZ [m]
Frame - axis 1	15.4	-0.15	-0.275	0.362
Lower arm - axis 2	7.6	0.059	-0.464	0.693
Upper arm - axis 3	20.9	0.102	0.016	0.061
Upper arm - axis 4	9.4	1.128	0.213	0.202
Wrist - axis 6	4	-0.0805	0	0

#### Arm load parameters for material handling



#### Note

If only the lower arm DressPack (base - axis 3) is installed, then exclude the arm load parameters for the upper arm - axis 4 and wrist - axis 6.

#### Arm load parameters IRB 6710-175/2.65 LID, LeanID MH

These tables show the values for the LeanID MH cable package - material handling.

IRB 6710-175/2.65 LID, LeanID MH	Mass [kg]	Mass CenterX [m]	Mass CenterY [m]	Mass CenterZ [m]
Frame - axis 1	8.1	-0.15	-0.275	0.362
Lower arm - axis 2	1.9	0.059	-0.464	0.693
Upper arm - axis 3	8.8	0.102	0.016	0.061
Upper arm - axis 4	5.7	0.91	0.213	0.202
Wrist - axis 6	2.1	-0.0805	0	0

#### Arm load parameters IRB 6710-175/2.95 LID, LeanID MH

These tables show the values for the LeanID MH cable package - material handling.

IRB 6710-175/2.95 LID, LeanID MH	Mass [kg]	Mass CenterX [m]	Mass CenterY [m]	Mass CenterZ [m]
Frame - axis 1	8.1	-0.15	-0.275	0.362
Lower arm - axis 2	1.9	0.059	-0.464	0.693
Upper arm - axis 3	8.8	0.102	0.016	0.061
Upper arm - axis 4	5.9	1.145	0.213	0.202
Wrist - axis 6	2.1	-0.0805	0	0

*Continues on next page*

## 3 Installation

### 3.11.1 DressPack - arm load parameters and LoadId

*Continued*

---

#### Procedures Step 1 - Arm load data

How to define the *Arm load* data is described in *Operating manual - OmniCore*.

All system parameters are described in *Technical reference manual - System parameters*.

Define the arm loads, typically:

- load:\_1
- load:\_2
- load:\_3

The used arm load is defined for each arm, irb\_1, irb\_2, and irb\_3.

---

#### Procedures Step 2 - load identification

It is recommended to use the load identification service routine to define the load data for an individual robot, as this method not only measures the mass but also the inertia of the tool.

Detailed in *Operating manual - OmniCore*.

	Action	Note
1	Check if the cable package prevents movements.	If the cable package prevent the motions.
2	If not: Run the load identification service routine.	The DressPack forces on the wrist will "increase" the load parameters, but this is anyhow a good approximation of the actual load case to be considered by the motion planning functions of the robot.
3	If the cable package prevent the motions: Remove the cable package.	
4	Make the load identification.	
5	Refit the cable package.	
6	Add the DressPack load manually.	See <a href="#">Procedures Step 1 - Arm load data on page 108</a> .



## 3.12 DressPack floor

### 3.12.1 Installation of DressPack floor

#### Configuration and connections of DressPack floor

The DressPack floor is made up of several components. Some of these components are specific to DressPack application, while others are used also in other applications.

The configuration of the components differs between different application types.

#### Types of application

Some typical applications are specified below:

Type of application	Description	Example of included components
H		Robot, single cabinet controller
S	Pneumatic gun	Robot, single cabinet controller
HS	Material handling and pneumatic gun	Robot, single cabinet controller, pedestal gun
Se	Servo gun	Robot, single cabinet controller
HSe	Material handling and servo gun	Robot, single cabinet controller, pedestal gun

#### Connection points

The cables and connections points between the components are all detailed and illustrated in the circuit diagram for the current application. See references to the circuit diagrams in [References on page 8](#).

#### Required equipment

Equipment, etc.	Article number	Note
DressPack floor	For spare part number see chapter: <ul style="list-style-type: none"> <li><a href="#">Spare parts on page 183</a>.</li> </ul>	A number of versions are available.
M12 dynamometric screwdriver SW15	09 99 000 0646 (article number at Harting Technology Group)	Used to tighten M12 Ethernet connectors.  <small>xx2200001261</small>
Standard toolkit	3HAC17290-7	The contents are defined in section <a href="#">Toolkits, DressPack on page 179</a> .

*Continues on next page*



## 3 Installation

### 3.12.1 Installation of DressPack floor

*Continued*

#### Installation

The procedure below details how to install the DressPack floor. Also refer to the current circuit diagram according to [References on page 8](#) and the [Spare parts on page 183](#) chapter.

	Action	Note
1	 <b>DANGER</b> Turn off all: <ul style="list-style-type: none"><li>• electric power supply</li><li>• hydraulic pressure supply</li><li>• air pressure supply</li></ul> to the robot, before entering the safe-guarded space.	
2	 <b>CAUTION</b> The cable package is sensitive to mechanical damage. Handle it with care in order to avoid damaging the cabling or the connectors.	
3	Determine which type of installation is to be done. Study the circuit diagram to decide which cables to connect.	The different types are shown in section <a href="#">Configuration and connections of DressPack floor on page 109</a> .
4	Whenever possible, run all cables/hoses in cable ducts or trenches. Make sure these meet the required standards.	Make sure: <ul style="list-style-type: none"><li>• no floor weld cable is routed along signal cabling to minimize the risk of interference.</li><li>• the duct/trench floor is free from sand and other contamination. This is to reduce the risk of damaging the cable insulation.</li><li>• no cables or hoses rub against any sharp corners which might damage them.</li></ul>
5	Do not bend or twist any cable or hose excessively.	Minimum bending radius is approximately 10x the cable or hose diameter.
6	Make sure all cable straps are tight enough to prevent the cable package from moving in any undesired way.	
7	Select which CP/CS cabling (customer power/customer signals) to be used.	Some versions include industrial buses. See circuit diagram and the <a href="#">Spare parts on page 183</a> chapter.

*Continues on next page*

	Action	Note
8	<p>Connect the CP/CS cable to the manipulator and controller cabinet connectors.</p> <p> <b>Note</b></p> <p>If the M12 Ethernet/PROFINET connector is not tightened correctly, there is a risk that the connector can loosen and the cable shield gets disconnected, which will require retightening with the correct torque tools. For secure connection, always tighten with correct torque and by using proper torque tool, with a preset torque of 0.4 Nm.</p> <p>Example for Phoenix connectors: assembly tool SAC BIT M12-D15 and torque screwdriver TSD 04 SAC.</p> <p>Example for Harting connectors: M12 dynamometric screwdriver SW15.</p>	<p>See circuit diagram and the <a href="#">Spare parts on page 183</a> chapter.</p> <p>Tightening torque, Ethernet/PROFINET M12: 0.4 Nm.</p>
9	<p>If used, connect the functional ground cable to the robot base and to the spot welding cabinet.</p>	<p>See circuit diagram.</p>

## 3 Installation

### 3.12.2 Inspection, DressPack floor

#### 3.12.2 Inspection, DressPack floor

##### General

In order to ensure adequate life of the equipment, it is vital that the cables and hoses are properly installed and operated correctly, with their movement patterns well within the acceptable limits.

This instruction details how to inspect the DressPack floor installation in this regard.

##### Procedure, process cable package

This section details each inspection to be carried out, not necessarily in any particular order unless stated.

	Action	Note
1	Make sure that the cable package is properly connected at the robot base as well as at the other end.	
2	Make sure that no hoses or cables, or parts thereof, are routed in such a way that they are subjected to wear, for example hoses being run over by fork lifts etc.	
3	Make sure that no cables or hoses rub against any sharp corners which might damage them.	
4	<p>Make sure all connection points are well tightened and sealed in order to avoid leaks.</p> <p> <b>Note</b></p> <p>If the M12 Ethernet/PROFINET connector is not tightened correctly, there is a risk that the connector can loosen and the cable shield gets disconnected, which will require retightening with the correct torque tools. For secure connection, always tighten with correct torque and by using proper torque tool, with a preset torque of 0.4 Nm.</p> <p>Example for Phoenix connectors: assembly tool SAC BIT M12-D15 and torque screwdriver TSD 04 SAC.</p> <p>Example for Harting connectors: M12 dynamic screwdriver SW15.</p>	Tightening torque, Ethernet/PROFINET M12: 0.4 Nm.

### 3.13 Test run after installation, maintenance, or repair

#### Safe handling

Use the following procedure after installation, maintenance, or repair, before initiating motion.



#### DANGER

Initiating motion without fulfilling the following aspects, may increase the risk for injury or cause damage to the robot.

	Action
1	Remove all tools and foreign objects from the robot and its working area.
2	Verify that the robot is properly secured to its position by all screws, before it is powered up.
3	Verify that any safety equipment installed to secure the position or restrict the robot motion during service activity is removed.
4	Verify that the fixture and work piece are well secured, if applicable.
5	Verify that all safety equipment is installed, as designed for the application.
6	Verify that no personnel are inside the safeguarded space.
7	If maintenance or repair has been done, verify the function of the part that was maintained.
8	Verify the application in the operating mode manual reduced speed.

#### Collision risks



#### CAUTION

When programming the movements of the robot, always identify potential collision risks before initiating motion.

**This page is intentionally left blank**

## 4 Maintenance

### 4.1 Introduction

---

#### Structure of this chapter

This chapter describes all the maintenance activities recommended for the DressPack IRB 6710.

It is based on the maintenance schedule found at the beginning of the chapter. The schedule contains information about required maintenance activities including intervals, and refers to procedures for the activities.

Each procedure contains all the information required to perform the activity, including required tools and materials.

The procedures are gathered in different sections and divided according to the maintenance activity.

---

#### Safety information

Observe all safety information before conducting any maintenance work.

There are general safety aspects that must be read through, as well as more specific safety information that describes the danger and safety risks when performing the procedures. Read the chapter [Safety on page 13](#) before performing any maintenance work.

The maintenance must be done by qualified personnel in accordance with the safety requirements set forth in the applicable national and regional standards and regulations.

## 4 Maintenance

### 4.2.1 Maintenance schedule

## 4.2 Maintenance schedule and component life

### 4.2.1 Maintenance schedule

#### General

The DressPack must be maintained regularly to ensure its function. The lifetime of a process cable package can be extended with the correct preventive maintenance activities. A daily visual check of the DressPack is highly recommended, which is normally performed by robot production personnel. It is essential that the person performing the visual check have basic training in ABB DressPack.

#### Wear parts

Wear parts should be replaced before considerable damage occurs to the process cable package. Replace wear parts before the part is completely damaged.

The following parts are considered as wear parts:

- Protection sleeves
- Protective hose
- Hose reinforcement
- Slide sleeves

#### Activities and intervals, standard equipment

The sections referred to in the table can be found in the different chapters for each maintenance activity.

The table below specifies the required maintenance activities and intervals:

Maintenance activity	Equipment	Interval	Detailed in section:
Inspection	All cables	Regularly <sup>i</sup>	<a href="#">Preventive inspection of all cables, DressPack on page 118</a>
Inspection	DressPack upper arm	Regularly <i>i</i>	<a href="#">Preventive inspection, DressPack upper arm on page 120</a>
Cleaning	DressPack upper arm	Regularly <i>i</i>	<a href="#">Cleaning, DressPack upper arm on page 124</a>

<sup>i</sup> "Regularly" implies that the activity is to be performed regularly, but the actual interval may not be specified by the robot manufacturer. The interval depends on the operation cycle of the robot, its working environment and movement pattern.

Generally, the more contaminated the environment, the closer the maintenance intervals. Also, the more demanding the movement pattern (sharper bending cable harness), the closer the intervals.

#### DressPack upper arm cable package

Based on experience, some parts are more exposed to wear. Therefore the DressPack upper arm cable package should be inspected according to the following schedule.

Interval	Action
Weekly	None
Every two weeks	Inspection wear

*Continues on next page*



Interval	Action
Every third month	Inspection
After changing movement pattern	Inspection

## 4 Maintenance

### 4.3.1 Preventive inspection of all cables, DressPack

## 4.3 Inspection activities

### 4.3.1 Preventive inspection of all cables, DressPack

#### Cables in the DressPack system

There are many different cables used in the DressPack system. The different cables used are listed in Spare parts section.

The inspection activities described below are a general description, and does not refer to any specific cable.

#### Required equipment

Equipment	Art. no.	Note
Standard toolkit	3HAC17290-7	The contents are defined in section <a href="#">Toolkits, DressPack on page 179</a> .

#### Inspection

The procedure below details how to inspect all cables included in the DressPack system.

This instruction applies to:

- DressPack upper arm and cables and hoses contained within
- DressPack lower arm and cables and hoses contained within
- DressPack floor and cables and hoses contained within.

	Action	Note
1	 <b>DANGER</b> Turn off all: <ul style="list-style-type: none"><li>• electric power supply</li><li>• hydraulic pressure supply</li><li>• air pressure supply</li></ul> to the robot, before entering the safe-guarded space.	
2	Make sure that the unit is clean and not overly contaminated.	Clean if required as detailed in section <a href="#">Cleaning, DressPack upper arm on page 124</a> .
3	Make sure that all bolts are fastened.	Recommended tightening torques are specified in section <a href="#">Screw joints on page 175</a> .
4	Make sure that all connections are fastened.	Re-tighten if necessary.
5	Check for mechanical wear, especially in areas where the cable/hose package rub against, or move close to, the robot or any other structure. Especially check any cable/hose package at the robot wrist.	Replace any worn items as detailed in the chapter <a href="#">Repair on page 127</a> . Re-adjust the assembly after installation.
6	If any of the protective sleeves are worn, rotate it or replace it.	

*Continues on next page*

### 4.3.1 Preventive inspection of all cables, DressPack *Continued*

	Action	Note
7	Check the attachments of the cable/hose package, to make sure they are properly secured.	Secure any loose items as detailed in the <a href="#">Installation on page 31</a> chapter.
8	Check all cable retainers, to make sure the cables/hoses are securely locked in the cable retainers.	

## 4 Maintenance

### 4.3.2 Preventive inspection, DressPack upper arm

### 4.3.2 Preventive inspection, DressPack upper arm

#### Location of DressPack upper arm

Upper arm MH3

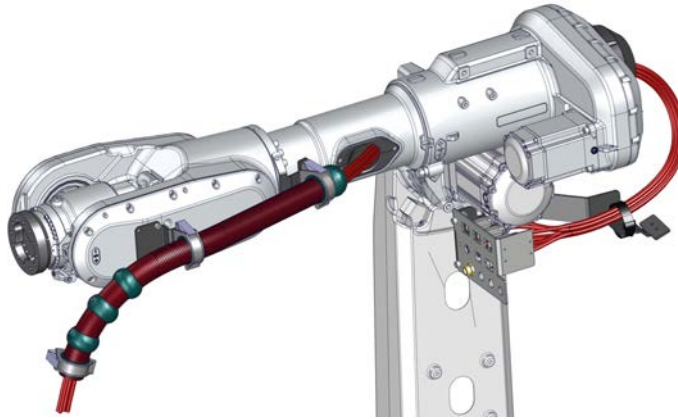

xx2300001106

LeanID MH, LeanID SW

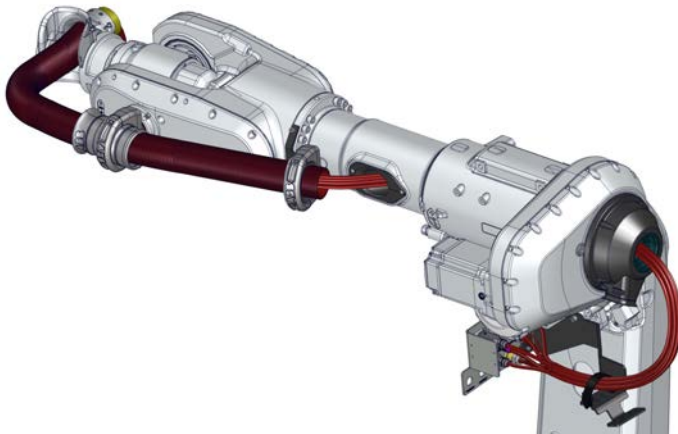

xx2300001108

#### Required equipment

Equipment	Article number	Note
Standard toolkit	3HAC17290-7	The contents are defined in section <a href="#">Toolkits, DressPack on page 179</a> .

*Continues on next page*

**Inspection - Robot standing still**

Use this procedure to inspect the DressPack when the robot is not in motion.

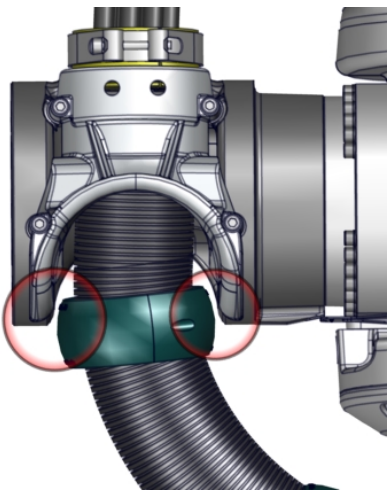
	Action	Note
1	 <b>DANGER</b> Turn off all: <ul style="list-style-type: none"> <li>• electric power supply</li> <li>• hydraulic pressure supply</li> <li>• air pressure supply</li> </ul> to the robot, before entering the safe-guarded space.	
2	Make sure that the DressPack is not contaminated.	If required, clean as detailed in section <a href="#">Cleaning, DressPack upper arm on page 124</a> .
3	Make sure that all bolts are fastened.	Recommended standard tightening torques are specified in section <a href="#">Screw joints on page 175</a> .
4	Check the position and state of the <i>protective sleeves</i> . Correct fitting of the protective sleeve at the axis-6 cable support: <ul style="list-style-type: none"> <li>• align the center of the radius (right side) of the axis-6 cable support, with the center of the radius of the corresponding protective sleeve. See figure!</li> </ul> Replace protective sleeves if needed. For correct fitting of the new protective sleeve, see instructions above for a correct fitting. The number of protective sleeves must remain the same (2 pcs).	 <p style="text-align: right; font-size: small;">xx2300001241</p>
5	Make sure all cable straps are tight enough to prevent the cable package from moving in an undesired way.	
6	Make sure that the velcro strap are not too tight. The cables should be able to twist.	
7	Make sure that the cable package is properly connected at: <ul style="list-style-type: none"> <li>• the connection plate</li> <li>• the robot base</li> <li>• the lower arm</li> <li>• the tool on the turning disc of the robot.</li> </ul>	
8	Make sure that all connections are fastened and that there are no leaks.	Re-tighten if necessary.
9	Make sure that the cable package is not cracked or damaged in any other way.	

Continues on next page

## 4 Maintenance

### 4.3.2 Preventive inspection, DressPack upper arm

*Continued*

	Action	Note
10	Check all cable clamps securing the process cable package and protective hose for tightness.	Tightening torques are specified either in: <ul style="list-style-type: none"><li>• Installation chapter (non-standard tightening torques) or</li><li>• standard tightening torque table (standard tightening torques).</li></ul>

#### Inspection - Reduced speed

The following procedure details how to inspect the DressPack upper arm when the robot is moving in reduced speed.



#### WARNING

A robot in motion is dangerous and may cause severe personal injuries, if safety procedures are not followed. Hence, all work must be performed outside the robots working range and outside the robots safety area.

Secure the following before work starts:

- Check that all emergency stops are fully functional.
- Close and activate all safety equipment (safety gates and/or safety curtains etc.).

	Action	Note
1	Make sure that no hoses or cables, or parts thereof, touch any part of the robot structure in a way that may cause wear.	
2	Make sure all cables and hoses move smoothly together during operation and that no part of the cable package moves in a different pattern.	

#### Inspection - Full speed

The following procedure details how to inspect the DressPack upper arm, when the robot is moving in full speed.



#### WARNING

A robot in motion is dangerous and may cause severe personal injuries, if safety procedures are not followed. Hence, all work must be performed outside the robots working range and outside the robots safety area.

Secure the following before work starts:

- Check that all emergency stops are fully functional.
- Close and activate all safety equipment (safety gates and/or safety curtains etc.).

	Action	Note
1	Make sure that no hoses or cables, or parts thereof, touch any part of the robot structure (or something in the vicinity of it) in a way that may cause wear.	

*Continues on next page*

	Action	Note
2	Make sure all cables and hoses move smoothly together during operation and that no part of the cable package moves in a different pattern.	

## 4 Maintenance

---

### 4.4.1 Cleaning, DressPack upper arm

## 4.4 Cleaning activities

### 4.4.1 Cleaning, DressPack upper arm

---

#### Location DressPack upper arm

Upper arm MH3

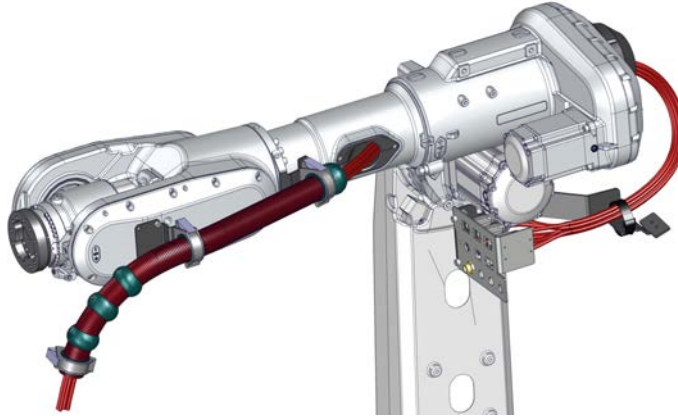

xx2300001106

LeanID MH, LeanID SW

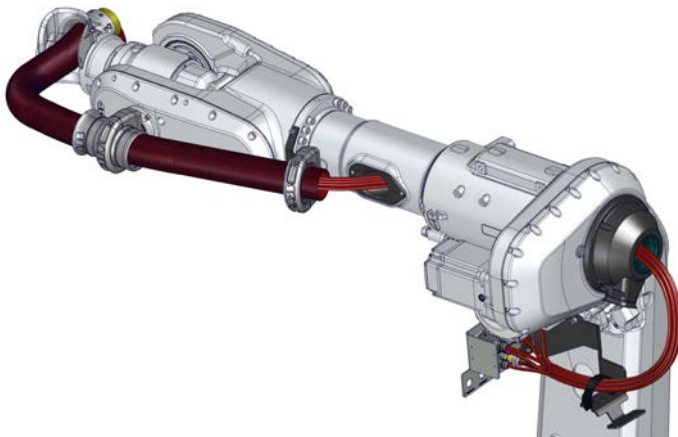

xx2300001108

---

#### Required equipment

Equipment	Art. no.	Note
Standard toolkit	3HAC17290-7	The contents are defined in section <a href="#">Toolkits, DressPack on page 179</a> .
Dry rag and medium soft brush		For cleaning the protective hose ribs.

*Continues on next page*



#### Cleaning

The procedure below details how to clean the DressPack upper arm.

	Action	Note
1	Clean the DressPack upper arm exterior, in order to avoid filling up the spaces between the ribs with debris. Make sure to clean any areas where any hoses bend or rub against the robot. If the harness is not cleaned sufficiently, breakage of the protective hose may result.	Only use equipment and cleaning agents as specified in section <a href="#">Required equipment on page 118</a> .
2	Clean the slide sleeves of any sort of contamination.	

**This page is intentionally left blank**

---

# 5 Repair

## 5.1 Introduction

---

### Structure of this chapter

This chapter describes repair activities for the DressPack IRB 6710. Each procedure contains the information required to perform the activity, for example spare parts numbers, required special tools, and materials.

**WARNING**

Repair activities not described in this chapter must only be carried out by ABB.

---

### Report replaced units

**Note**

When replacing a part on the DressPack IRB 6710, report to your local ABB the serial number, the article number, and the revision of both the replaced unit and the replacement unit.

This is particularly important for safety equipment to maintain the safety integrity of the installation.

---

### Safety information

Make sure to read through the chapter [Safety on page 13](#) before commencing any service work.

## 5 Repair

---

### 5.2.1 Replacing the lower arm MH cable package

## 5.2 DressPack cable packages axis 1-3

### 5.2.1 Replacing the lower arm MH cable package

---

#### Location of cable package

The location of the lower arm MH cable package is shown in the figure.



xx2300001074

---

#### Required spare parts



#### Note

The spare part numbers that are listed in the table can be out of date. See the latest spare parts of the DressPack IRB 6710 via myABB Business Portal, [www.abb.com/myABB](http://www.abb.com/myABB).

Spare part	Article number	Note
Harness lower arm MH Paracom	3HAC083476-001	Parallel. All attachments except velcro straps included.

*Continues on next page*

5.2.1 Replacing the lower arm MH cable package  
Continued

Spare part	Article number	Note
Harness lower arm MH Paramulti	3HAC083482-001	EtherNet. All attachments except velcro straps included.

Required service parts



Consumable	Article number	Note
Locking liquid	-	Loctite 2400 (or equivalent Loctite 243)
Velcro strap	3HAC12625-1	5 pcs

Required tools and equipment

Equipment, etc.	Article number	Note
M12 dynamometric screwdriver SW15	09 99 000 0646 (article number at Harting Technology Group)	Used to tighten M12 Ethernet connectors.
Standard toolkit	-	Content is defined in section <a href="#">Standard toolkit on page 179</a> .

Removing the cable package

Use this procedure to remove the lower arm MH cable package.

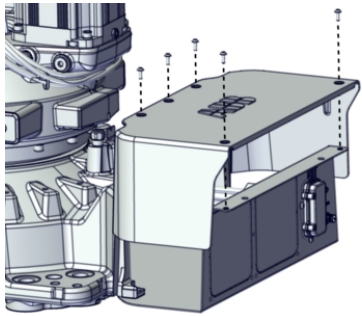
	Action	Note
1	 <p><b>DANGER</b></p> <p>Turn off all:</p> <ul style="list-style-type: none"> <li>• electric power supply</li> <li>• hydraulic pressure supply</li> <li>• air pressure supply</li> </ul> <p>to the robot, before entering the safeguarded space.</p>	
2	 <p><b>CAUTION</b></p> <p>The cable package is sensitive to mechanical damage. Handle it with care in order to avoid damaging the cabling or the connectors.</p>	
3	Remove the rear cover plate.	 <p>xx210000981</p>

Continues on next page

## 5 Repair

### 5.2.1 Replacing the lower arm MH cable package

Continued

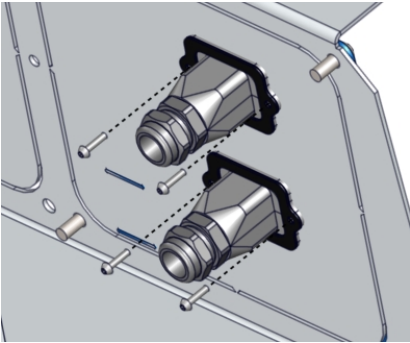
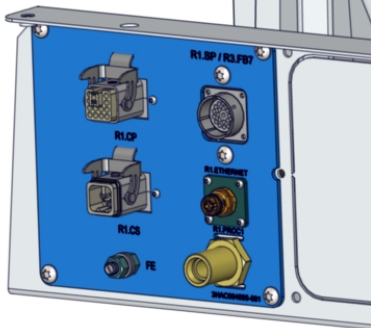
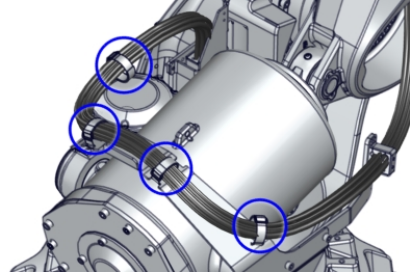
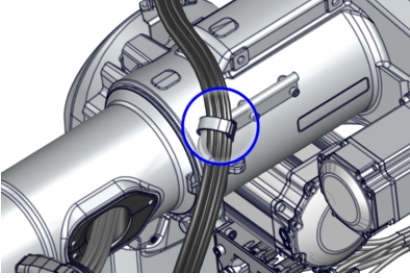
	Action	Note
4	Remove the R1.CP and R1.CS connectors by removing the attachment screws.	 <p data-bbox="995 674 1102 689">xx2300001077</p> <p data-bbox="995 703 1407 757">Torx pan head screw: M3x12 Stainless steel A2-70 (2 pcs/connector)</p>
5	Disconnect the rest of the connectors from the customer plate.	 <p data-bbox="995 1131 1102 1146">xx2300001081</p>
6	Open the velcro straps.	 <p data-bbox="995 1464 1102 1480">xx2300001083</p>  <p data-bbox="995 1780 1102 1796">xx2300001084</p>

Continues on next page

5.2.1 Replacing the lower arm MH cable package  
Continued

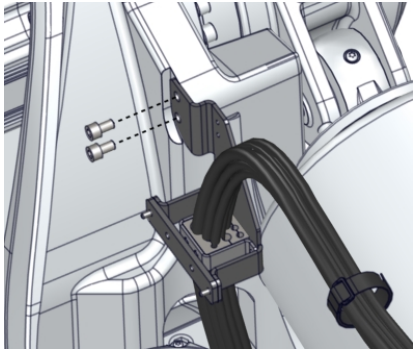
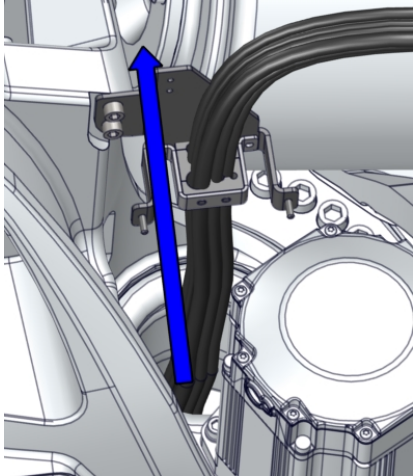
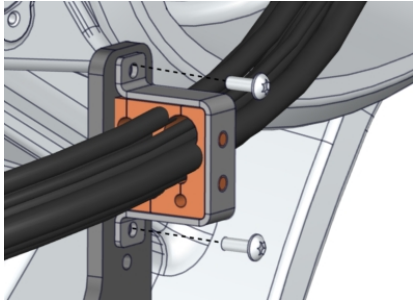
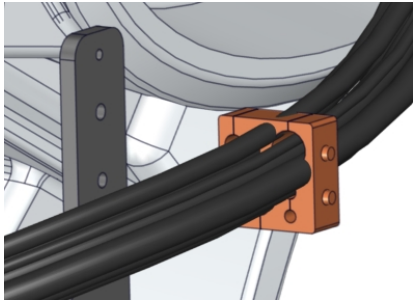
	Action	Note
7	Remove the cable bracket at the top of the frame, by removing the attachment screws	 <p>xx2300001086</p>
8	Pull the lower end of the cable package out through the center hole in the axis-1 gearbox. Order of disassembly: 1 Hoses 2 Signal cables	 <p>xx2300001186</p>
9	Remove the cable bracket from the side bracket arm, by removing the attachment screws.	 <p>xx2300001235</p>
10	Remove the rubber clamp from the cable package and reuse it during refitting.	 <p>xx2300001234</p>

Continues on next page

## 5 Repair

### 5.2.1 Replacing the lower arm MH cable package

*Continued*

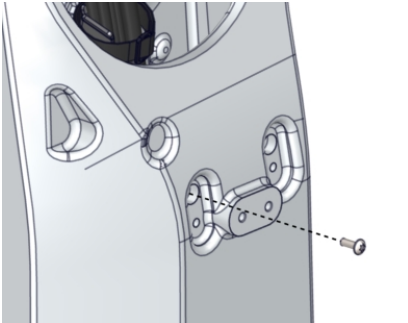
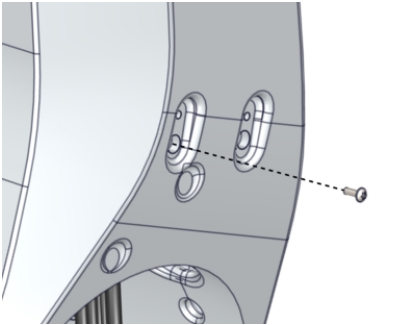
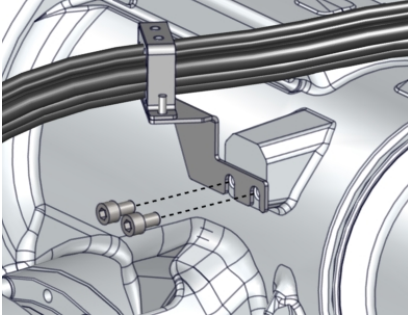
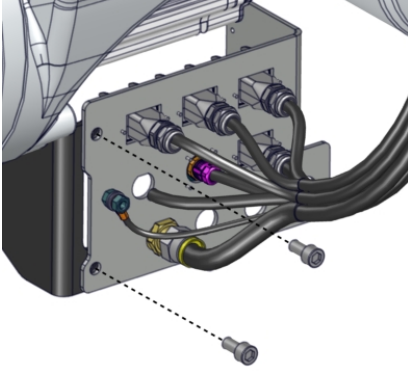
	Action	Note
11	Remove the cable brackets inside the lower arm, by removing the attachment screws.	 <p>xx2300001088</p>  <p>xx2300001089</p>
12	Remove the cable bracket on top of the arm house, by removing the attachment screws.	 <p>xx2300001090</p>
13	Remove the connection plate from the axis-3 mounting plate, by removing the attachment screws.	 <p>xx2300001091</p>

*Continues on next page*

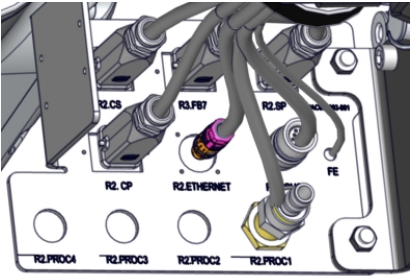
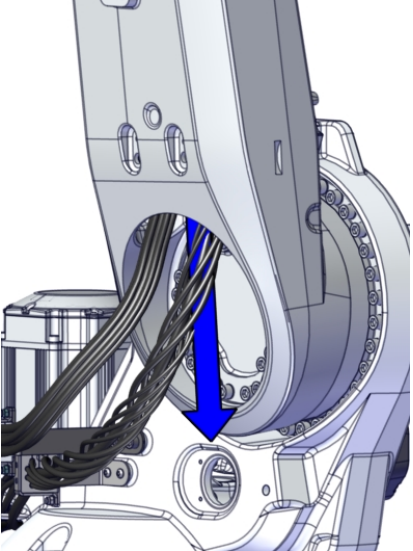

5.2.1 Replacing the lower arm MH cable package  
Continued

	Action	Note
14	Disconnect all connectors from the connection plate.	 <p>xx2300001107</p>
15	Use caution and pull the cable package out of the lower arm.	 <p>xx2100002727</p>
16	Put the cable package somewhere safe.	

**Refitting the cable package**

Use this procedure to refit the lower arm MH cable package.

	Action	Note
1	How to fit the lower arm MH cable package, see section <a href="#">Fitting the lower arm MH cable package on page 58</a> .	

## 5 Repair

### 5.2.2 Replacing the lower arm SW cable package

### 5.2.2 Replacing the lower arm SW cable package

#### Location of cable package

The location of the lower arm SW cable package is shown in the figure.

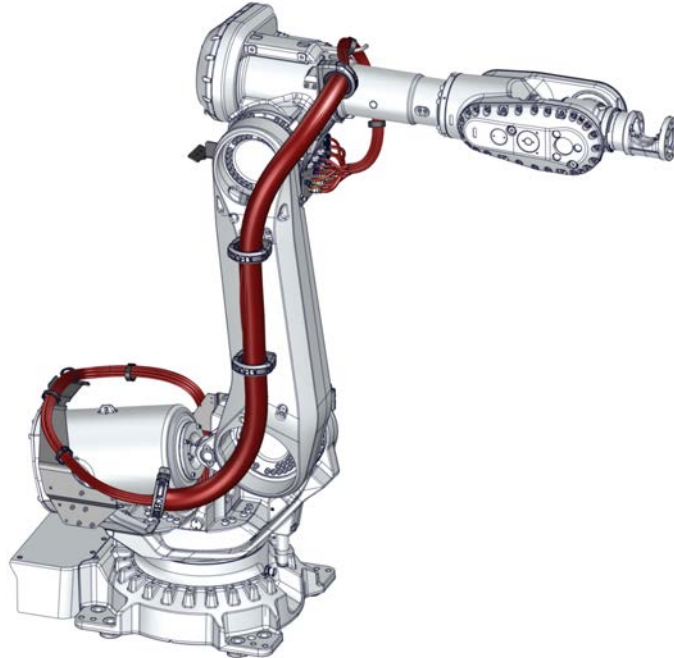

xx2300001045

#### Required spare parts



#### Note

The spare part numbers that are listed in the table can be out of date. See the latest spare parts of the DressPack IRB 6710 via myABB Business Portal, [www.abb.com/myABB](http://www.abb.com/myABB).

Spare part	Article number	Note
Harness lower arm SW Paracom Servo	3HAC086512-001	Parallel-Servo. All attachments except velcro straps included.
Harness lower arm SW Paramulti Servo	3HAC086514-001	EtherNet-Servo. All attachments except velcro straps included.

#### Required service parts

Consumable	Article number	Note
Locking liquid	-	Loctite 2400 (or equivalent Loctite 243)
Velcro strap	3HAC12625-1	6 pcs
Cable ties	-	

Continues on next page

Required tools and equipment

Equipment, etc.	Article number	Note
M12 dynamometric screwdriver SW15	09 99 000 0646 (article number at Harting Technology Group)	Used to tighten M12 Ethernet connectors.
Standard toolkit	-	Content is defined in section <a href="#">Standard toolkit on page 179</a> .



Removing the cable package

Use this procedure to remove the lower arm SW cable package.



Note

When removing the upper parts of the ball joint housings, make sure that the small o-ring still is left on the attachment screw. The purpose of the o-ring is to keep the screw from falling off the housing when the upper part is removed.

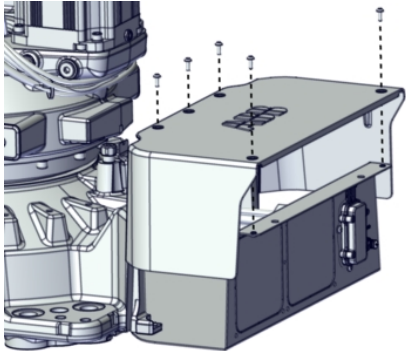
	Action	Note
1	Move the robot to a comfortable working position.	
2	 <b>DANGER</b> Turn off all: <ul style="list-style-type: none"> <li>• electric power supply</li> <li>• hydraulic pressure supply</li> <li>• air pressure supply</li> </ul> to the robot, before entering the safeguarded space.	
3	 <b>CAUTION</b> The cable package is sensitive to mechanical damage. Handle it with care in order to avoid damaging the cabling or the connectors.	
4	Remove the rear cover plate.	 xx210000981

Continues on next page

## 5 Repair

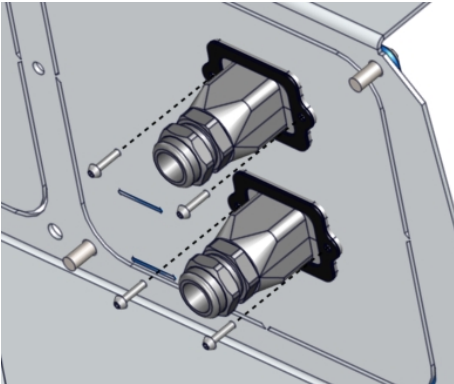
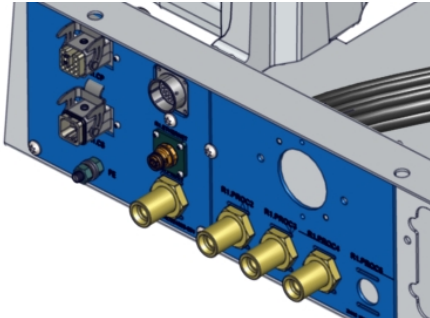
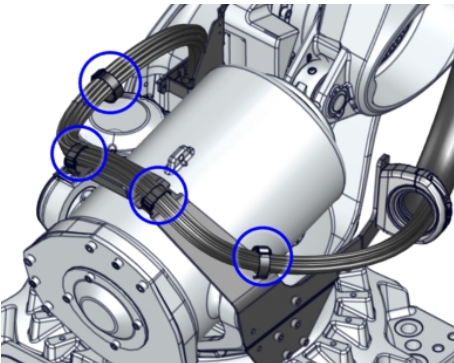
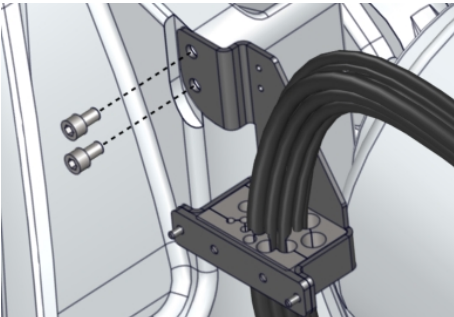

### 5.2.2 Replacing the lower arm SW cable package

Continued

	Action	Note
5	Remove the R1.CP and R1.CS connectors by removing the attachment screws.	 xx2300001077 Torx pan head screw: M3x12 Stainless steel A2-70 (2 pcs/connector)
6	Disconnect the rest of the connectors from the customer and process plate.	 xx2300001093
7	Open the velcro straps.	 xx2300001095
8	Remove the cable bracket at the top of the frame, by removing the attachment screws	 xx2300001094

Continues on next page

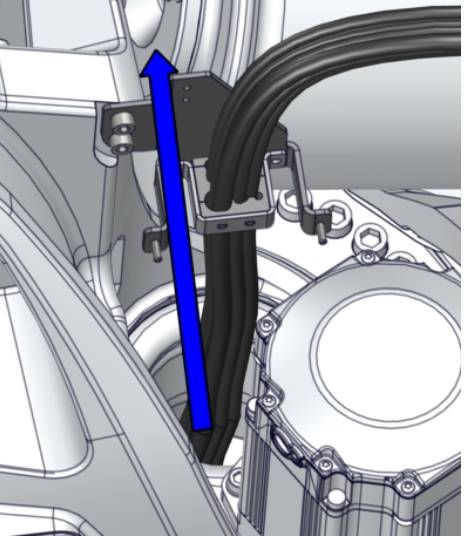
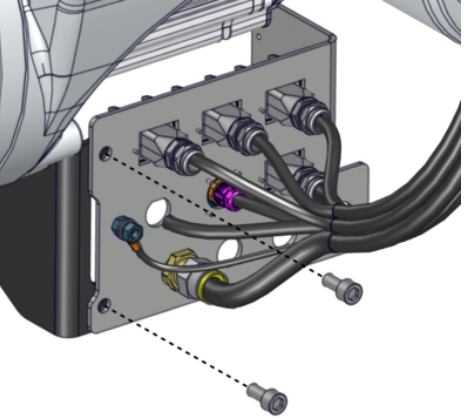
5.2.2 Replacing the lower arm SW cable package  
Continued

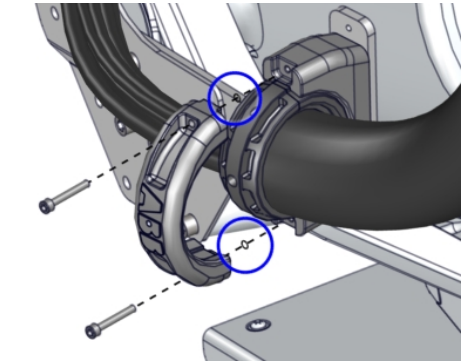

	Action	Note
9	Cut the cable tie that fastens the R2.FB7 cable to the motor cabling.	
10	<p>Pull the lower end of the cable package out through the center hole in the axis-1 gearbox.</p> <p>Order of disassembly:</p> <ol style="list-style-type: none"> <li>1 Hoses</li> <li>2 Weld cables</li> <li>3 Remaining cables</li> </ol>	 <p>xx2300001186</p>
11	Remove the connection plate from the axis-3 mounting plate, by removing the attachment screws.	 <p>xx2300001091</p>
12	<p>Remove the upper part of the ball joint housing at the side bracket.</p> <p> <b>Note</b></p> <p>Be careful not to loose the small o-ring on the attachment screw. It keeps the screw from falling off the housing when removed.</p>	 <p>xx2300001046</p>

Continues on next page

## 5 Repair

### 5.2.2 Replacing the lower arm SW cable package

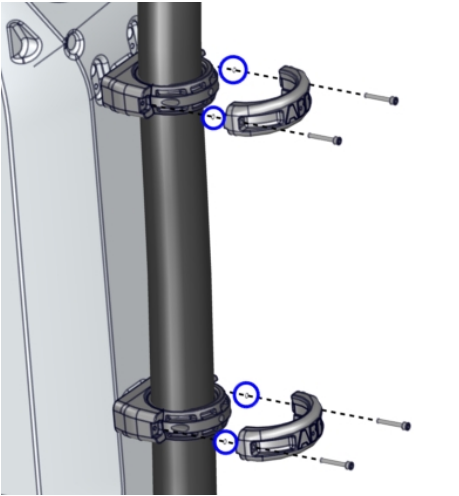
Continued

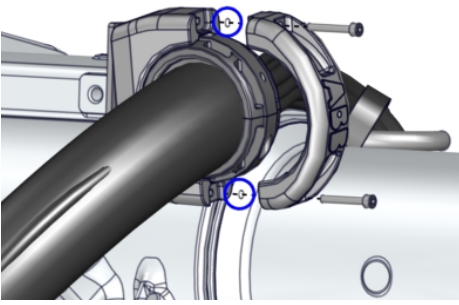
	Action	Note
13	<p>Remove the upper parts of the ball joint housings on the lower arm.</p> <p> <b>Note</b></p> <p>Be careful not to loose the small o-ring on the attachment screw. It keeps the screw from falling off the housing when removed.</p>	 <p>xx2300001103</p>
14	<p>Remove the upper part of the ball joint housing on top of the upper arm.</p> <p> <b>Note</b></p> <p>Be careful not to loose the small o-ring on the attachment screw. It keeps the screw from falling off the housing when removed.</p>	 <p>xx2300001101</p>
15	Put the cable package somewhere safe.	

### Refitting the cable package

Use this procedure to refit the lower arm SW cable package.

	Action	Note
1	<p>How to fit the lower arm SW cable package, see section <a href="#">Fitting the lower arm SW cable package on page 67</a>.</p>	

## 5.3 DressPack cable packages axis 3-6

### 5.3.1 Replacing the upper arm MH3 cable package

#### Location of cable package

The location of the upper arm MH3 cable package is shown in the figure below.

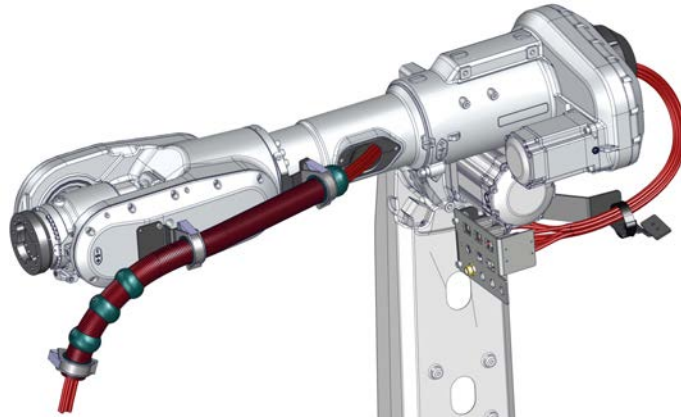

xx2300001106

#### Required spare parts



#### Note

The spare part numbers that are listed in the table can be out of date. See the latest spare parts of the DressPack IRB 6710 via myABB Business Portal, [www.abb.com/myABB](http://www.abb.com/myABB).

Spare part	Article number	Note
Harness upper arm MH3 Paracom	IRB 6710-210/2.65: 3HAC083533-001 IRB 6710-200/2.95: 3HAC083534-001	Parallel. All attachments except velcro straps included.
Harness upper arm MH3 Paramulti	IRB 6710-210/2.65: 3HAC083539-001 IRB 6710-200/2.95: 3HAC083540-001	EtherNet. All attachments except velcro straps included.

#### Required service parts

Consumable	Article number	Note
Locking liquid	-	Loctite 2400 (or equivalent Loctite 243)
Cable grease	3HAC14807-1	Optitemp RB2
Velcro strap	3HAC024008-001	

*Continues on next page*



## 5 Repair

### 5.3.1 Replacing the upper arm MH3 cable package

*Continued*

#### Required tools and equipment

Equipment, etc.	Article number	Note
M12 dynamometric screwdriver SW15	09 99 000 0646 (article number at Harting Technology Group)	Used to tighten M12 Ethernet connectors.
Standard toolkit	-	Content is defined in section <a href="#">Standard toolkit on page 179</a> .

#### Removing the upper arm MH3 cable package

Use this procedure to remove the cable package.

#### Preparations

	Action	Note
1	Move the robot to a comfortable working position.	
2	 <b>DANGER</b> Turn off all: <ul style="list-style-type: none"><li>• electric power supply</li><li>• hydraulic pressure supply</li><li>• air pressure supply</li></ul> to the robot, before entering the safeguarded space.	

#### Removing the cable package at the wrist and upper arm

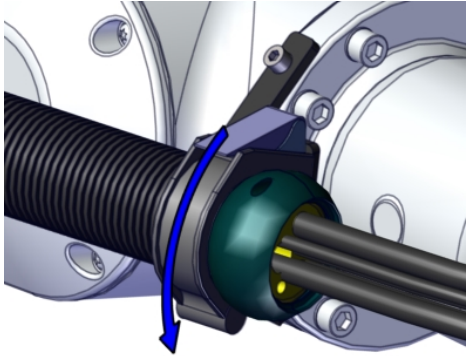
	Action	Note
1	 <b>CAUTION</b> The cable package is sensitive to mechanical damage. Handle it with care in order to avoid damaging the cabling or the connectors.	
2	Open the ball joint housing on the wrist flange.	 <small>xx2100002755</small>

*Continues on next page*

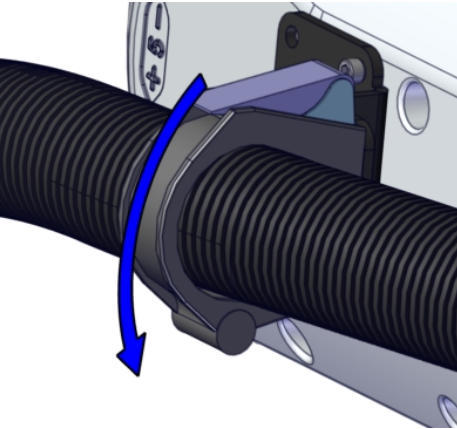
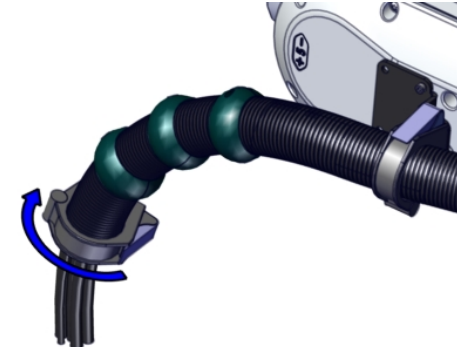
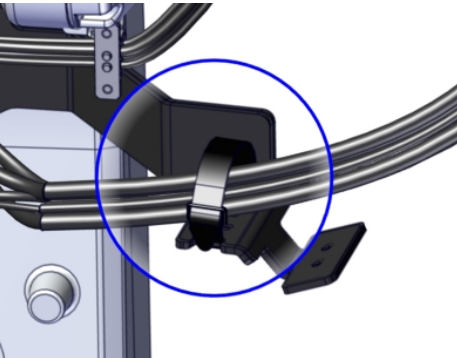

5.3.1 Replacing the upper arm MH3 cable package  
Continued

	Action	Note
3	Open the ball joint housing on the wrist cover.	 xx2100002756
4	Open the ball joint housing in the front, fitted on the customer equipment, depending on what equipment is used.	 xx2100002757
5	Open the velcro strap on the mounting plate.	 xx2100002758



Continues on next page

## 5 Repair

### 5.3.1 Replacing the upper arm MH3 cable package

*Continued*

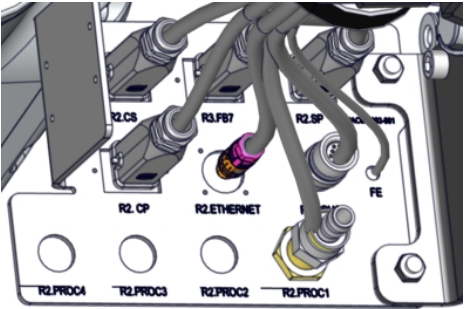
#### Removing the cable package from the robot

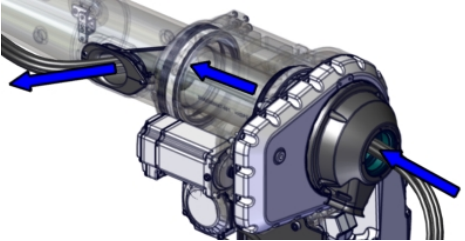
	Action	Note
1	Disconnect the cable connectors on the axis-3 connection plate.	 <p>xx2300001107</p>
2	<p>Use caution and pull the cable package out through the tube and insert.</p> <p> <b>Tip</b></p> <p>This procedure is best done by two persons working together - one pushing the cable package into the tube from the back and one pulling it out at the arm insert.</p> <p> <b>Note</b></p> <p>There will be cable grease on the cable package!</p>	 <p>xx2100002728</p>
3	Put the cable package somewhere safe.	

#### Refitting the upper arm MH3 cable package

Use this procedure to refit the cable package.

	Action	Note
1	How to fit the upper arm MH3 cable package is described in section <a href="#">Fitting the upper arm MH3 cable package on page 76</a> .	

### 5.3.2 Replacing the LeanID MH / LeanID SW cable package

#### Location of the cable package

The location of the LeanID MH/SW cable package is shown in the figure.

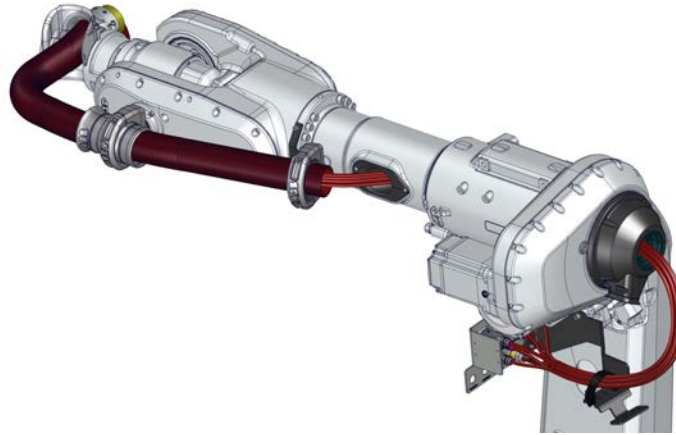

xx2300001108

#### Required spare parts



#### Note

The spare part numbers that are listed in the table can be out of date. See the latest spare parts of the DressPack IRB 6710 via myABB Business Portal, [www.abb.com/myABB](http://www.abb.com/myABB).

Spare part	Article number	Note
Harness upper arm LeanID MH Paracom	IRB 6710-175/2.65 LID: 3HAC083515-001 IRB 6710-175/2.95 LID: 3HAC083516-001	Parallel. All attachments except velcro straps included.
Harness upper arm LeanID MH Paramulti	IRB 6710-175/2.65 LID: 3HAC083521-001 IRB 6710-175/2.95 LID: 3HAC083522-001	EtherNet. All attachments except velcro straps included.
Harness upper arm LeanID SW Paracom Servo	IRB 6710-175/2.65 LID: 3HAC086529-001 IRB 6710-175/2.95 LID: 3HAC086530-001	Parallel-Servo. All attachments except velcro straps included.
Harness upper arm LeanID SW Paramulti Servo	IRB 6710-175/2.65 LID: 3HAC086533-001 IRB 6710-175/2.95 LID: 3HAC086534-001	EtherNet-Servo. All attachments except velcro straps included.

*Continues on next page*

## 5 Repair

### 5.3.2 Replacing the LeanID MH / LeanID SW cable package

*Continued*

#### Required service parts

Consumable	Article number	Note
Locking liquid	-	Loctite 2400 (or equivalent Loctite 243)
Cable grease	3HAC14807-1	Optitemp RB2
Velcro strap	3HAC024008-001	

#### Required tools and equipment

Equipment, etc.	Article number	Note
M12 dynamometric screwdriver SW15	09 99 000 0646 (article number at Harting Technology Group)	Used to tighten M12 Ethernet connectors.
Standard toolkit	-	Content is defined in section <a href="#">Standard toolkit on page 179</a> .

#### Removing the cable package

Use this procedure to remove the LeanID MH/SW cable package.

#### Preparations





	Action	Note
1	Move the robot to a comfortable working position.	
2	 <b>DANGER</b> Turn off all: <ul style="list-style-type: none"><li>• electric power supply</li><li>• hydraulic pressure supply</li><li>• air pressure supply</li></ul> to the robot, before entering the safeguarded space.	

#### Removing the cable package at the wrist and upper arm

	Action	Note
1	 <b>CAUTION</b> The cable package is sensitive to mechanical damage. Handle it with care in order to avoid damaging the cabling or the connectors.	

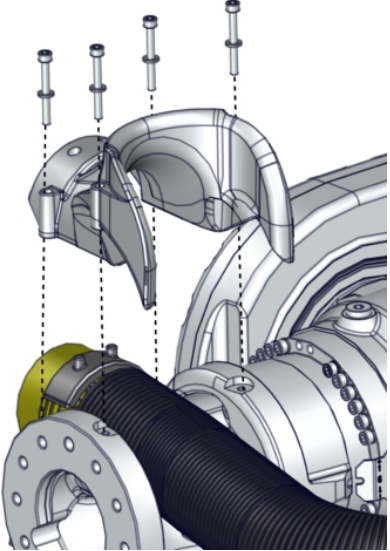
*Continues on next page*

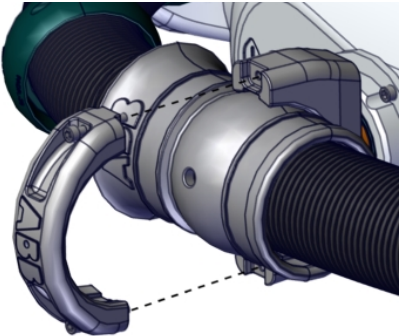
5.3.2 Replacing the LeanID MH / LeanID SW cable package  
Continued

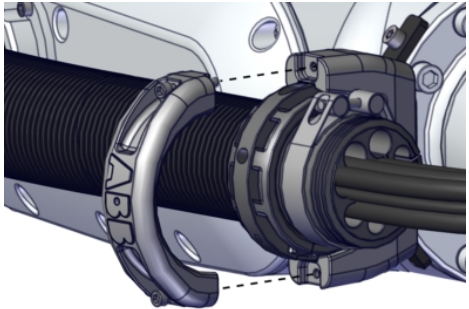
	Action	Note
2	Remove the axis 6 cable support.	 <p data-bbox="970 902 1078 925">xx2300001211</p>
3	Remove the upper part of the ball joint housing on the wrist cover.   <b>Note</b> Be careful not to loose the small o-ring on the attachment screw. It keeps the screw from falling off the housing when removed.	 <p data-bbox="970 1339 1078 1361">xx2100002711</p>
4	Remove the upper part of the ball joint housing on the wrist flange.   <b>Note</b> Be careful not to loose the small o-ring on the attachment screw. It keeps the screw from falling off the housing when removed.	 <p data-bbox="970 1776 1078 1798">xx2100002709</p>
5	Remove the upper end of the cable harness from the open ball joint housings and put it on the floor.	

Continues on next page

## 5 Repair

### 5.3.2 Replacing the LeanID MH / LeanID SW cable package

Continued

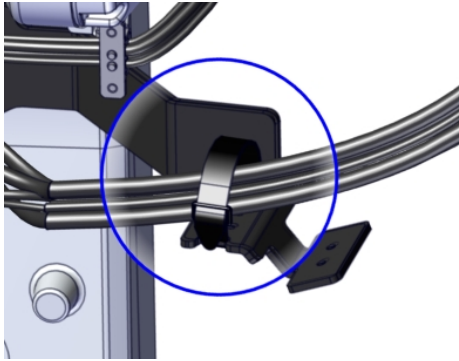
	Action	Note
6	Open the strap at the axis-3 mounting plate.	 xx2100002758

#### Removing the protection hose (protection type Foundry Plus)

Use this procedure to remove the protection hose from robots with protection type Foundry Plus.

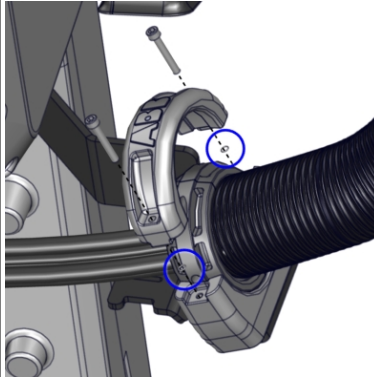
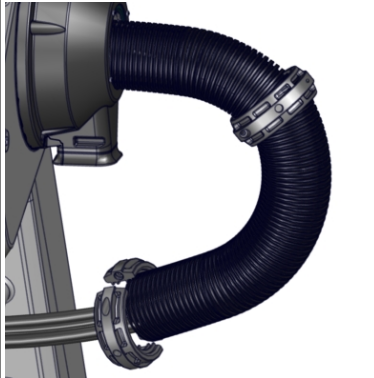
	Action	Note
1	Remove the upper part of the ball joint housing.  <b>Note</b> Be careful not to loose the small o-ring on the attachment screw. It keeps the screw from falling off the housing when removed.	 xx2300001288
2	Remove the clamp jaw from the end of the hose.	 xx2300001285

Continues on next page

5.3.2 Replacing the LeanID MH / LeanID SW cable package  
Continued

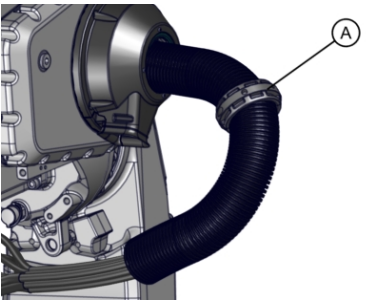
	Action	Note
3	For LeanID SW: Remove the clamp jaw (A)	 <p>xx2300001245</p> <p>A Clamp jaw for cable package LeanID SW</p>

Weld connector

Only valid for cable package LeanID SW.

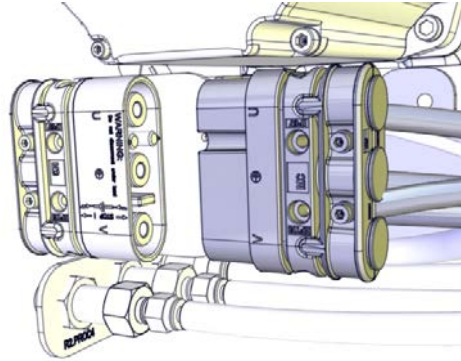
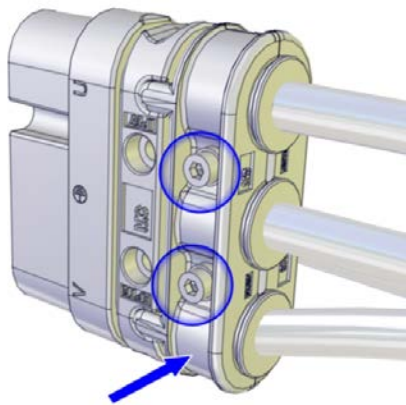
	Action	Note
1	Remove the two M5 screws securing the weld connector to the connection plate and unplug the weld connector.	 <p>xx1200000075</p>
2	Remove the cable strain relief from the weld connector.	 <p>xx1200000058</p> <p>Attachment screws: M5x25 quality 8.8-A2F (2 pcs)</p>

Continues on next page



## 5 Repair

### 5.3.2 Replacing the LeanID MH / LeanID SW cable package

Continued

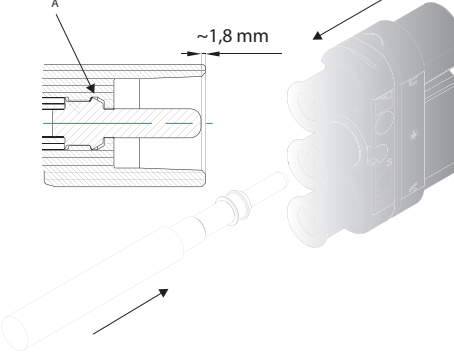
	Action	Note		
3	<p>Unplug the connectors in the weld connector.</p> <p>Use caution and pull (manually) the cables with the crimped-on contact part out off the insulation from the back. See figure!</p>	<p>This will facilitate the removal of the cable package through the tube in the upper arm.</p>  <p>xx130000835</p> <table border="1" data-bbox="943 775 1398 819"> <tr> <td data-bbox="943 775 991 819">A</td> <td data-bbox="995 775 1398 819">Detent</td> </tr> </table>	A	Detent
A	Detent			

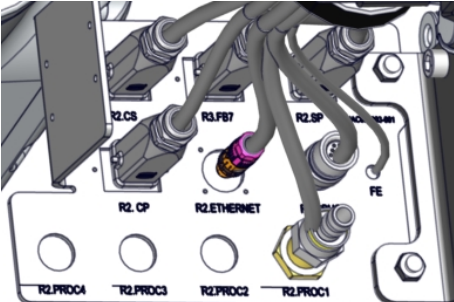
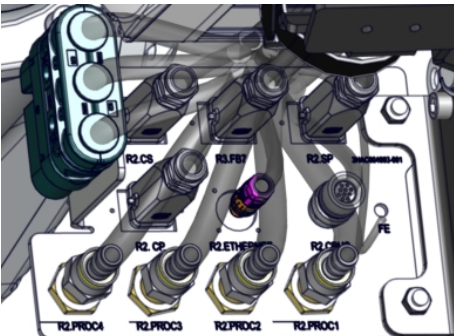

#### Removing the cable package from the robot

	Action	Note
1	<p>Disconnect the cable connectors on the axis-3 connection plate.</p>	<p><b>LeanID MH:</b></p>  <p>xx2300001107</p> <p><b>LeanID SW:</b></p>  <p>xx2300001109</p>

Continues on next page

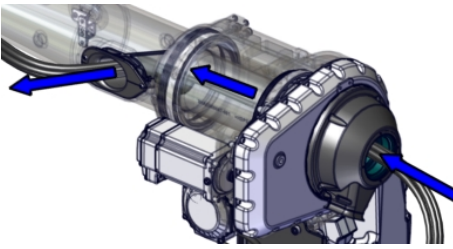

5.3.2 Replacing the LeanID MH / LeanID SW cable package  
Continued

	Action	Note
2	<p>Use caution and pull the cable package out through the tube and insert.</p> <p>This is best done following this order:</p> <ol style="list-style-type: none"> <li>1 Welding cables</li> <li>2 Remaining cables</li> </ol> <p> <b>Tip</b></p> <p>This procedure is best done by two persons working together - one pushing the cable package into the tube from the back and one pulling it out at the arm insert.</p> <p> <b>Note</b></p> <p>There will be cable grease on the cable package!</p>	 <p>xx2100002728</p>
3	Put the cable package somewhere safe.	

**Refitting the cable package**

Use this procedure to refit the LeanID MH/SW cable package.

	Action	Note
1	<p>How to fit the LeanID MH/SW cable package is described in section <a href="#">Fitting the LeanID MH / LeanID SW cable package on page 83</a>.</p>	

## 5 Repair

### 5.4.1 Replacing the protection hose for upper arm MH3 cable package

## 5.4 Protection hose

### 5.4.1 Replacing the protection hose for upper arm MH3 cable package

#### Location of protection hose, upper arm

The protection hose, upper arm is located as shown in the figure.

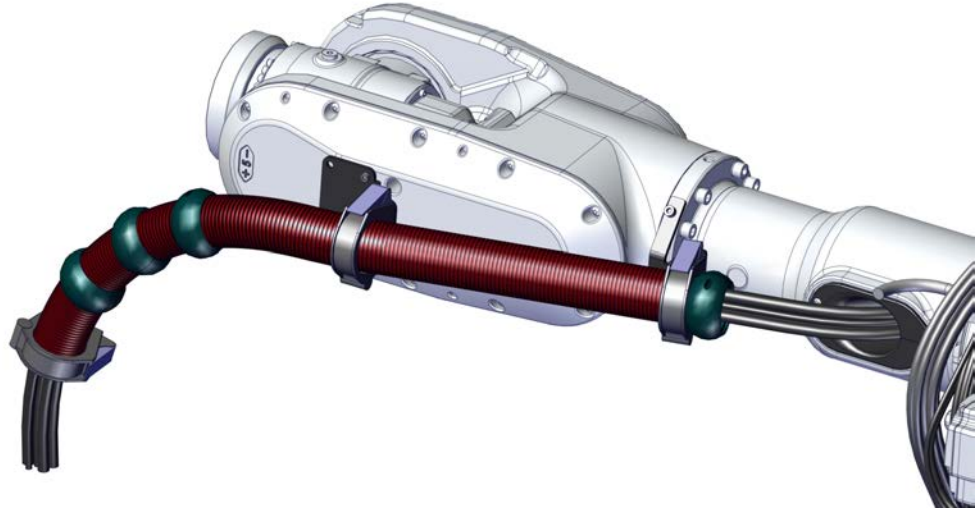

xx2100002762

#### Required spare parts



#### Note

The spare part numbers that are listed in the table can be out of date. See the latest spare parts of the DressPack IRB 6710 via myABB Business Portal, [www.abb.com/myABB](http://www.abb.com/myABB).

Spare part	Article number	Note
Protection hose	3HAC024692-052	Purchased per meter. Required length: 1,630 mm.
Protective sleeve, rotary	3HAC032661-001	
Cable retainer	3HAC084915-001	

#### Required service parts

Consumable	Article number	Note
Cable grease	3HAC14807-1	Optitemp RB2

#### Required tools and equipment

Equipment, etc.	Article number	Note
Standard toolkit	-	Content is defined in section <a href="#">Standard toolkit on page 179</a> .

*Continues on next page*

5.4.1 Replacing the protection hose for upper arm MH3 cable package  
Continued

Removing the protection hose

Use these procedures to remove the protection hose

Step 1 - Cable package from the front



**Note**

Do not open the ball joint housing on the wrist flange at this point. It will be easier to remove the front end of the protection hose if the cable package still is fitted to that ball joint housing.

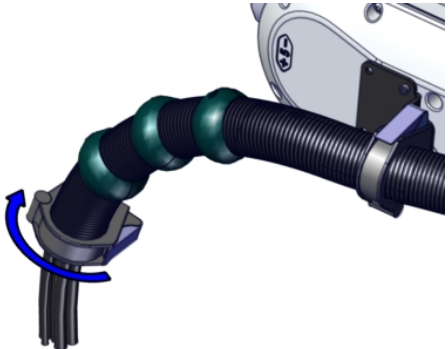

	Action	Note
1	Move the robot to a comfortable working position.	
2	 <b>DANGER</b> Turn off all: <ul style="list-style-type: none"> <li>• electric power supply</li> <li>• hydraulic pressure supply</li> <li>• air pressure supply</li> </ul> to the robot, before entering the safe-guarded space.	
3	Open the ball joint housing at the front.	 <p>xx2100002757</p>

Continues on next page

## 5 Repair

### 5.4.1 Replacing the protection hose for upper arm MH3 cable package

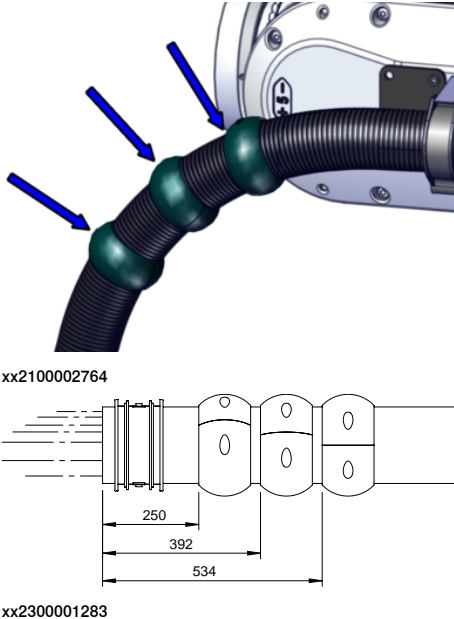
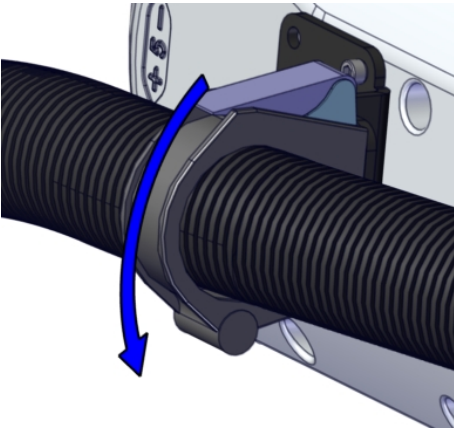

Continued

	Action	Note
4	Remove the protective sleeves from the hose.	 <p>xx2100002764</p> <p>xx2300001283</p>
5	Open the ball joint housing on the wrist cover.	 <p>xx2100002756</p>
6	Put some clean plastic, paper or similar on the floor, big enough to keep the cable package from any contamination in the continued removal process of the protection hose.	
7	Put the cable package on the floor.  <b>Note</b> Let the cable package stay fitted in the ball joint housing on the wrist flange during this procedure.	

Continues on next page

5.4.1 Replacing the protection hose for upper arm MH3 cable package  
Continued

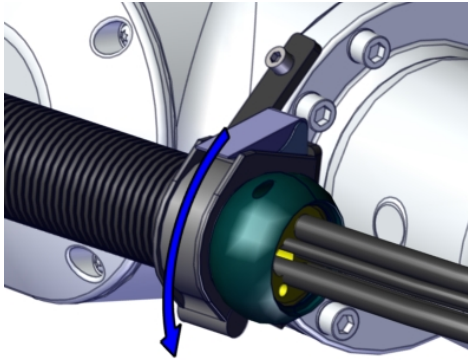
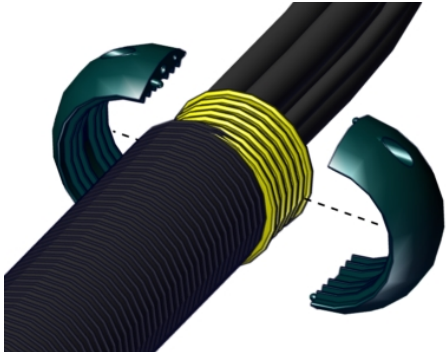
Step 2 - Cable and hose retainer (back end)

	Action	Note
1	Open the ball joint housing on the wrist flange.	 <p>xx2100002755</p>
2	Remove the protective sleeve that secures the cable and hose retainer.	 <p>xx2100002763</p>
3	Remove the cable and hose retainer.	 <p>xx1400000349</p>
4	Pull carefully out cables and remove the protection hose.	<p>Best performed in this order:</p> <ol style="list-style-type: none"> <li>1 Cables with the smallest connectors</li> <li>2 Cables with the biggest connectors.</li> </ol>

Continues on next page

## 5 Repair





### 5.4.1 Replacing the protection hose for upper arm MH3 cable package

Continued

#### Refitting the protection hose

Use these procedures to refit the protection hose

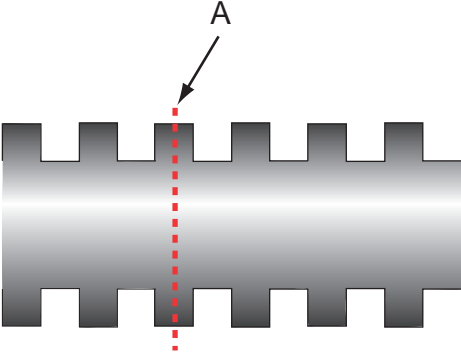
##### Step 1 - Cable and hose retainer

	Action	Note
1	 <p><b>DANGER</b></p> <p>Turn off all:</p> <ul style="list-style-type: none"> <li>• electric power supply</li> <li>• hydraulic pressure supply</li> <li>• air pressure supply</li> </ul> <p>to the robot, before entering the safe-guarded space.</p>	
2	<p>Cut the new protection hose to the length required.</p>  <p><b>Note</b></p> <p>Place the cut on top of a ridge. See A in the figure!</p>	<p>Protection hose: 3HAC024692-052</p>  <p>xx0300000061</p>
3	<p>Put some cable grease on cables and hoses on the area where they run through the protection hose.</p>	<p>Cable grease: 3HAC14807-1 (Optitemp RB2)</p>
4	<p>Push the cables and hoses into the protection hose.</p>	<p>Best performed in this order:</p> <ol style="list-style-type: none"> <li>1 Cables with the biggest connectors</li> <li>2 Hoses</li> <li>3 Cables with the smallest connectors.</li> </ol>
5	<p>Make sure that cables and hoses are not twisted.</p>	
6	 <p><b>CAUTION</b></p> <p>No lubrication is allowed in the cable retainer. Make sure to clean cables, hoses and the cable retainer, if necessary.</p>	<p>Cable retainer: 3HAC084915-001</p>  <p>xx1400000349</p>

Continues on next page

5.4.1 Replacing the protection hose for upper arm MH3 cable package  
Continued

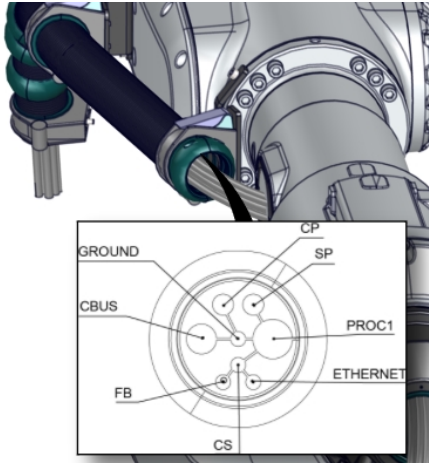
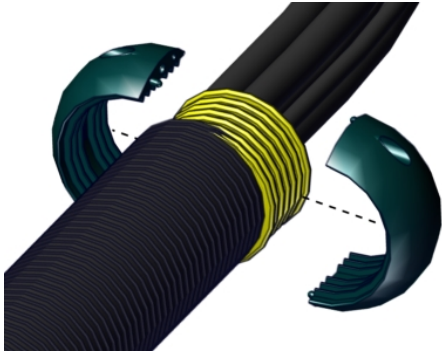
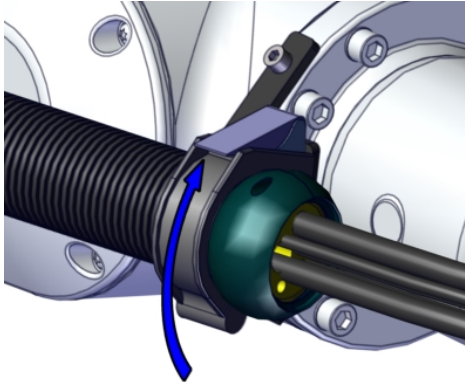
	Action	Note
7	Arrange the cables and put them in their position in the cable retainer.	 <p>The diagram shows a cable being inserted into a retainer. An inset diagram shows the terminal layout with labels: GROUND, CBUS, FB, CS, CP, SP, PROC1, and ETHERNET.</p> <p>xx2300001282</p>
8	Fit the protective sleeve over the cable retainer.	<p>Protective sleeve, rotary: 3HAC032661-001</p>  <p>xx2100002763</p>
9	Lift the cable package up to the ball joint housing at the wrist flange and close the ball joint housing.	 <p>xx2100002759</p>

Continues on next page

## 5 Repair

### 5.4.1 Replacing the protection hose for upper arm MH3 cable package

*Continued*

#### Step 3 - Cable package

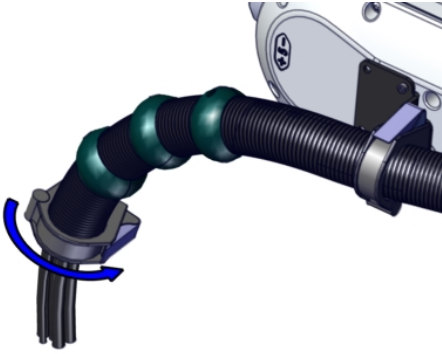
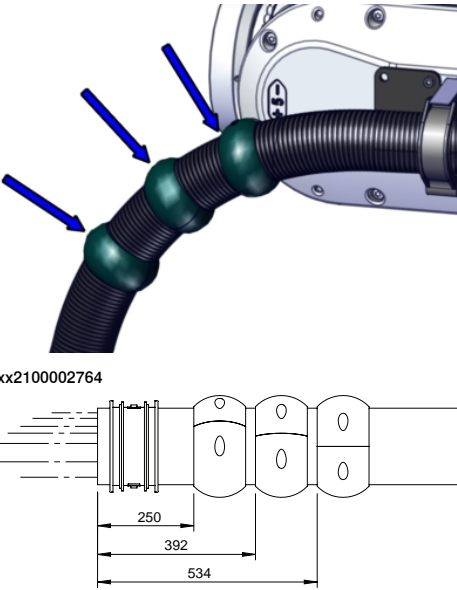
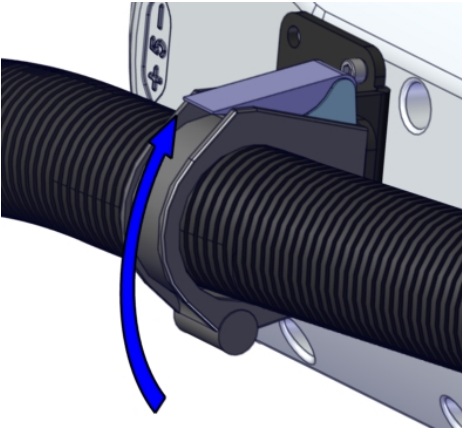

	Action	Note
1	Fit and close the ball joint housing at the front.	 <p>xx2100002765</p>
2	Measure the distance from the hose end and refit the protective sleeves as shown in the figure.	 <p>xx2100002764</p> <p>xx2300001283</p>
3	Secure the cable package in the ball joint housing on the wrist cover.	 <p>xx2100002760</p>

*Continues on next page*



### 5.4.1 Replacing the protection hose for upper arm MH3 cable package

*Continued*

	Action	Note
4	 <b>CAUTION</b> When the cable package has been fitted on the upper arm, always check potential collision risks between the cable package and the wrist as well as between the cable package and any equipment fitted on the wrist, before restarting the normal production.	
5	Turn on the power and run the present programming at a <i>very slow</i> speed, while checking all movements for collision risk between cable package and wrist.	
6	<b>Only valid for Paramulti:</b> Connect the functional ground to the customer tool Profinet I/O and or tool changer to increase equipotential bonding.	
7	 <b>DANGER</b> Make sure all safety requirements are met when performing the first test run. See <a href="#">Test run after installation, maintenance, or repair on page 113</a> .	

## 5 Repair

### 5.4.2 Replacing the protection hose for LeanID MH cable package

#### 5.4.2 Replacing the protection hose for LeanID MH cable package

##### Location of protection hose, upper arm

The protection hose, upper arm is located as shown in the figure.

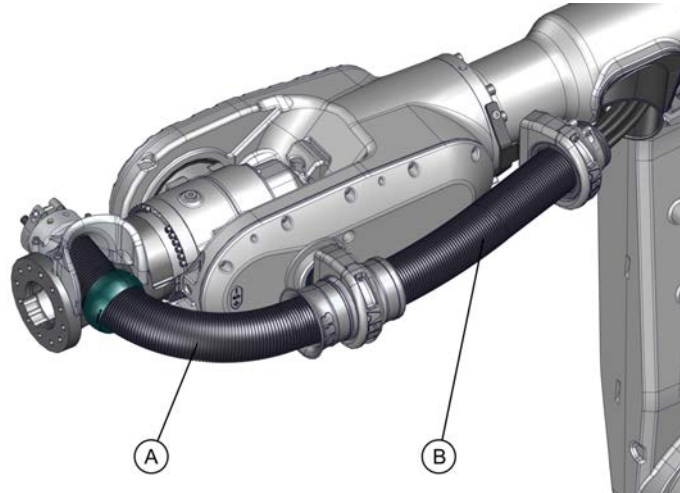

xx2300001284

A	Front end, 950 mm
B	Back end, 570 mm

##### Required spare parts



##### Note

The spare part numbers that are listed in the table can be out of date. See the latest spare parts of the DressPack IRB 6710 via myABB Business Portal, [www.abb.com/myABB](http://www.abb.com/myABB).

Spare part	Article number	Note
Protection hose	3HAC080953-001	Purchased per meter.
Hose reinforcement funnel	3HAC032916-001	Order 2 pcs to get both parts.
Protective sleeve, rotary	3HAC032660-001	
Cable clamp, half	3HAC024692-051	Delivered complete (both parts).
Cable clamp, insert	3HAC042483-001	Order 2 pcs to get both parts.
Cable retainer	3HAC083950-001	
Middle jaw	3HAC14290-1	

##### Required service parts

Consumable	Article number	Note
Cable grease	3HAC14807-1	Optitemp RB2

Continues on next page

5.4.2 Replacing the protection hose for LeanID MH cable package  
Continued

Required tools and equipment

Equipment, etc.	Article number	Note
Standard toolkit	-	Content is defined in section <a href="#">Standard toolkit on page 179</a> .

Removing the protection hose



Use these procedures to remove the protection hose

Step 1 - Cable package from the front



Note

Do not open the ball joint housing on the wrist flange at this point. It will be easier to remove the front end of the protection hose if the cable package still is fitted to that ball joint housing.

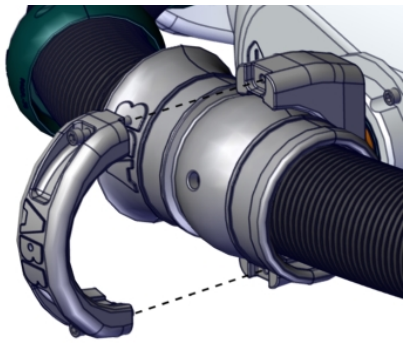

	Action	Note
1	Move the robot to a comfortable working position.	
2	 <b>DANGER</b> Turn off all: <ul style="list-style-type: none"> <li>• electric power supply</li> <li>• hydraulic pressure supply</li> <li>• air pressure supply</li> </ul> to the robot, before entering the safe-guarded space.	
3	Remove the upper part, of the ball joint housing on the wrist cover.   <b>Note</b> Be careful not to loose the small o-ring on the attachment screw. It keeps the screw from falling off the housing when removed.	  xx2100002711

Continues on next page

## 5 Repair

### 5.4.2 Replacing the protection hose for LeanID MH cable package

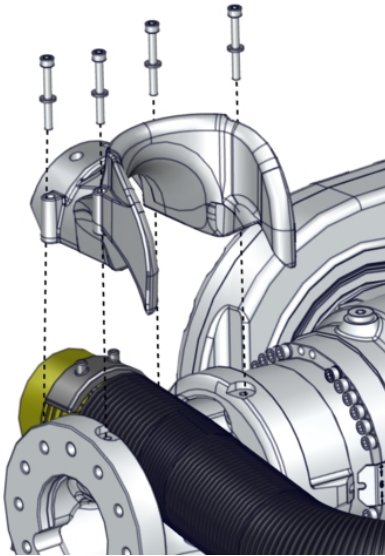
Continued

	Action	Note
4	Remove the axis 6 cable support.	 <p data-bbox="943 904 1050 922">xx2300001211</p>
5	Put some clean plastic, paper or similar on the floor, big enough to keep the cable package from any contamination in the continued removal process of the protection hose.	
6	Put the cable package on the floor.  <b>Note</b> Let the cable package stay fitted in the ball joint housing on the wrist flange during this procedure.	

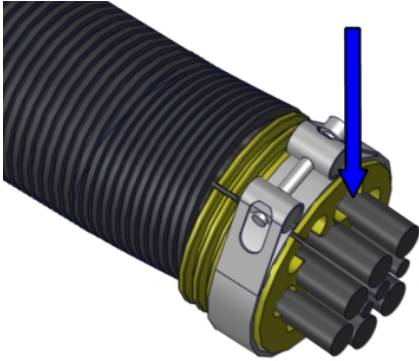

#### Step 2 - Cable and hose retainer (wrist) & hose reinforcement funnel

	<b>Note</b>	Let the cable package stay fitted in the ball joint housing on the upper arm tube during this procedure.
---	-------------	--

	Action	Note
1	Mark the cables to find the correct mounting position later on.	 <p data-bbox="943 2002 1050 2020">xx2300001301</p>

Continues on next page

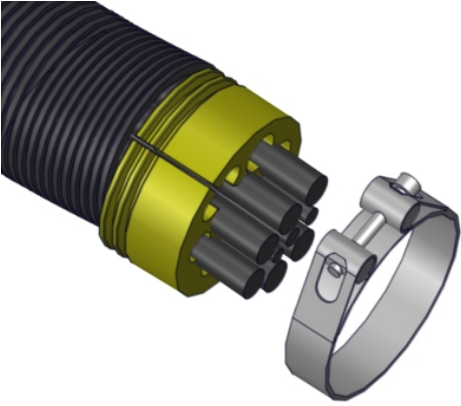
5.4.2 Replacing the protection hose for LeanID MH cable package  
Continued

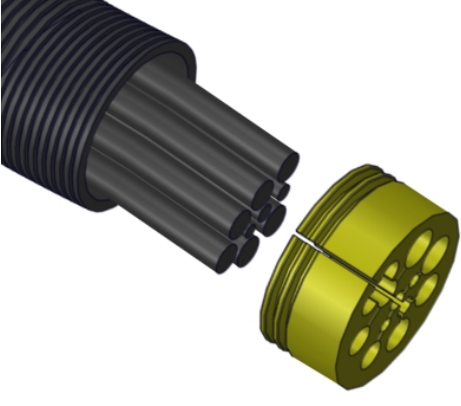
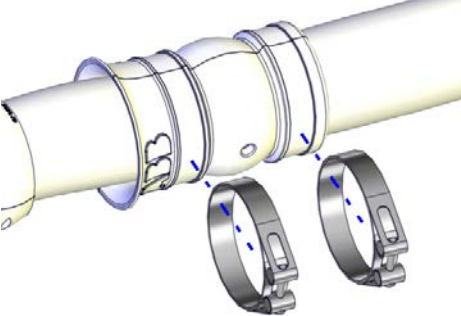
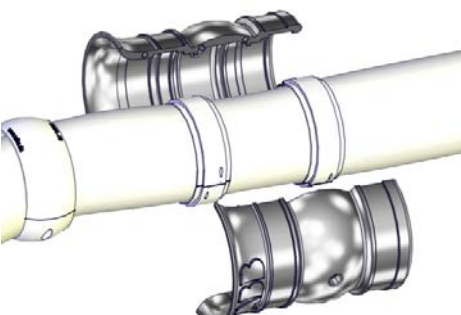
	Action	Note
2	<p>Remove the hose clamp securing the cable and hose retainer.</p> <p> <b>CAUTION</b></p> <p>Make sure the fillers stay in the empty positions in the retainer.</p>	 <p>xx2300001302</p>
3	<p>Remove the cable and hose retainer.</p> <p> <b>CAUTION</b></p> <p>Do not contaminate the cable retainer with cable grease.</p> <p> <b>CAUTION</b></p> <p>Make sure the fillers stay in the empty positions in the retainer.</p>	 <p>xx2300001303</p>
4	<p>Remove the hose clamps (2 pcs) securing the hose reinforcement funnel.</p>	 <p>xx1400000209</p>
5	<p>Remove the hose reinforcement funnel (two parts).</p>	 <p>xx1400000210</p>

Continues on next page

## 5 Repair

### 5.4.2 Replacing the protection hose for LeanID MH cable package

*Continued*

	Action	Note
6	Pull carefully out cables and remove the protection hose.	Best performed in this order: 1 Cables with the smallest connectors. 2 Hoses 3 Cables with the biggest connectors.

#### Step 3 - Cable and hose retainer (upper arm tube)

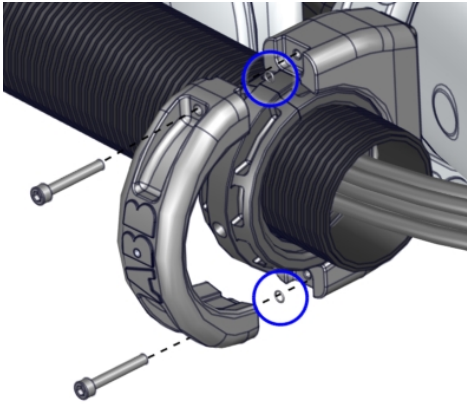
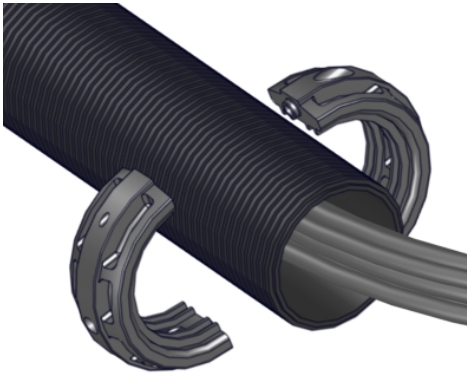
	Action	Note
1	Remove the upper part of the ball joint housing on the wrist flange.   <b>Note</b>  Be careful not to loose the small o-ring on the attachment screw. It keeps the screw from falling off the housing when removed.	  <small>xx2300001304</small>
2	Remove the clamp jaw.	  <small>xx2300001305</small>
3	Pull carefully out cables and remove the protection hose.	Best performed in this order: 1 Cables with the smallest connectors. 2 Cables with the biggest connectors.



*Continues on next page*

5.4.2 Replacing the protection hose for LeanID MH cable package  
Continued

Refitting the protection hose

Use these procedures to refit the protection hose

Step 1 - Cable and hose retainer (upper arm tube)

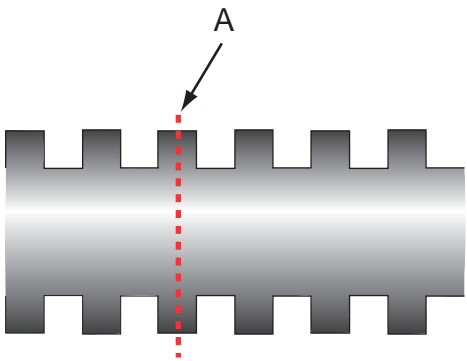
	Action	Note
1	 <b>DANGER</b> Turn off all: <ul style="list-style-type: none"> <li>• electric power supply</li> <li>• hydraulic pressure supply</li> <li>• air pressure supply</li> </ul> to the robot, before entering the safe-guarded space.	
2	Cut the new protection hose to the length required.  <b>Note</b> Place the cut on top of a ridge. See A in the figure!	Protection hose: 3HAC080953-001  xx0300000061 Cut for the back end: 570 mm
3	Put some cable grease on cables and hoses on the area where they run through the protection hose and hose reinforcement funnel.	Cable grease: 3HAC14807-1 (Optitemp RB2)
4	Push the cables into the protection hose.	Best performed in this order: <ol style="list-style-type: none"> <li>1 Cables with the biggest connectors</li> <li>2 Cables with the smallest connectors.</li> </ol>
5	Make sure that cables are not twisted.	

Continues on next page

## 5 Repair

### 5.4.2 Replacing the protection hose for LeanID MH cable package

Continued

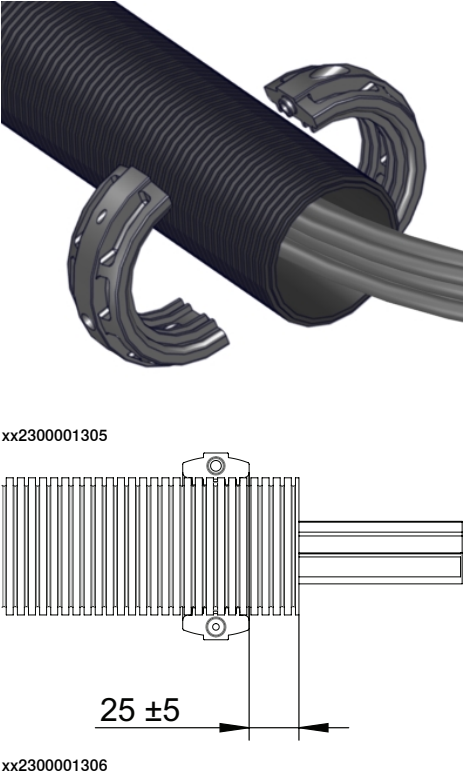
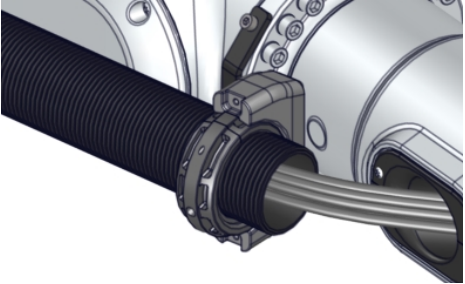
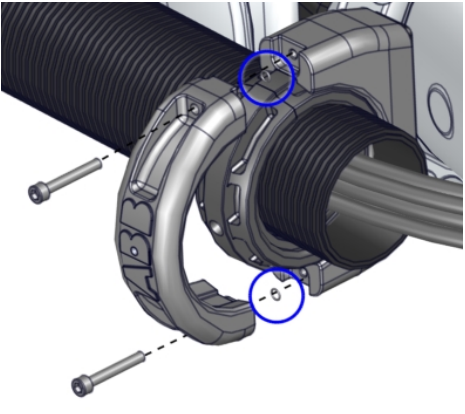

	Action	Note
6	Fit the cable clamp.	<p data-bbox="944 315 1366 371">Cable clamp, insert: 3HAC042483-001 (Order 2 pcs to get both parts.)</p>  <p data-bbox="944 801 1050 819">xx2300001305</p> <p data-bbox="1040 1070 1123 1102">25 ± 5</p> <p data-bbox="944 1128 1050 1146">xx2300001306</p>
7	Lift the cable package up and put the clamp jaw in the ball joint housing.	 <p data-bbox="944 1473 1050 1491">xx2300001309</p>
8	Secure the cable package in the ball joint housing.	 <p data-bbox="944 1939 1050 1957">xx2300001304</p>

Continues on next page

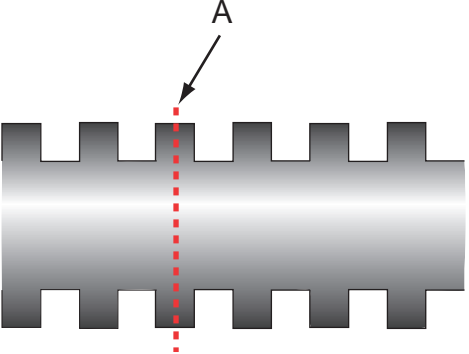

5.4.2 Replacing the protection hose for LeanID MH cable package  
Continued

Step 2 - Hose reinforcement funnel

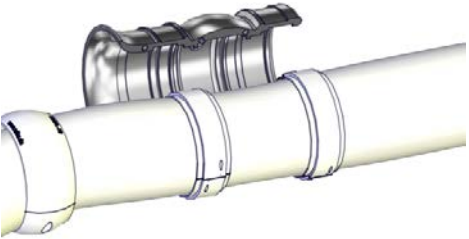
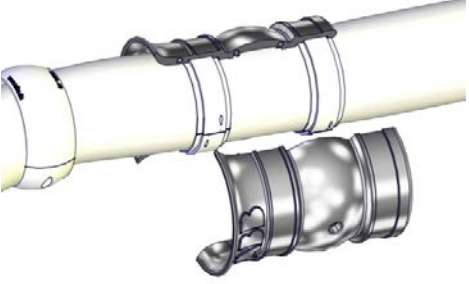
	Action	Note
1	<p>Cut the new protection hose (for the front end) to the length required.</p> <p> <b>Note</b></p> <p>Place the cut on top of a ridge. See A in the figure!</p>	 <p>xx030000061</p> <p>Front end: 950 mm</p>
2	<p>Use caution and push cables into the part of the protection hose.</p>	<p>Best performed in this order:</p> <ol style="list-style-type: none"> <li>1 Cables with the biggest connectors</li> <li>2 Cables with the smallest connectors.</li> </ol>
3	<p>Make sure that cables and hoses are not twisted.</p>	
4	<p>Fit the middle jaws in one of the hose reinforcement funnel halves.</p> <p> <b>Note</b></p> <p>The side of the hose reinforcement funnel which has the bigger outer diameter shall be turned towards the wrist.</p>	 <p>xx140000350</p>
5	<p>Fit the other half and secure the hose reinforcement funnel with the hose clamps.</p>	 <p>xx140000351</p>

Continues on next page

## 5 Repair

### 5.4.2 Replacing the protection hose for LeanID MH cable package

Continued

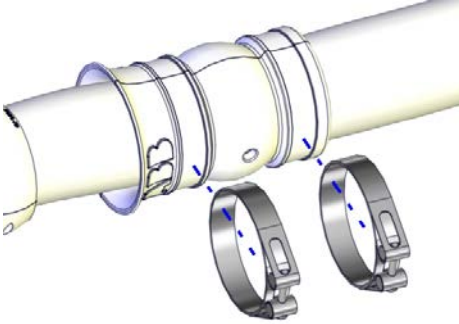
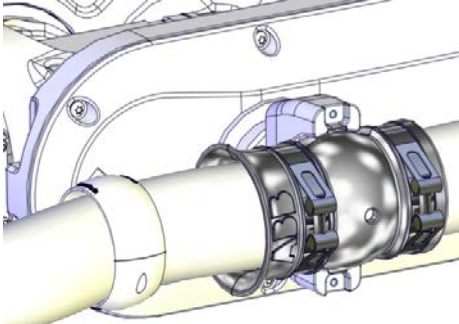

	Action	Note
6	Secure the hose reinforcement funnel with the hose clamps.	 <p>xx140000209</p>
7	Check that the screws on the hose clamps are fitted in the correct position.	 <p>xx140000222</p>

#### Step 3 - Cable and hose retainer (wrist)

	Action	Note
1	<p>Clean the cables and hoses from any lubrication at the mounting points of the cable and hose retainer.</p> <p>Also clean the retainer, if necessary.</p> <p> <b>CAUTION</b></p> <p>No lubrication is allowed in the cable retainer. Make sure to clean cables, hoses and the cable retainer, if necessary.</p>	

Continues on next page

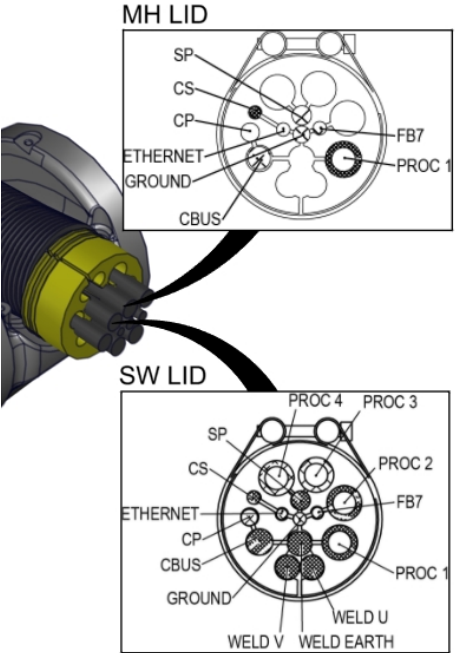
5.4.2 Replacing the protection hose for LeanID MH cable package  
Continued

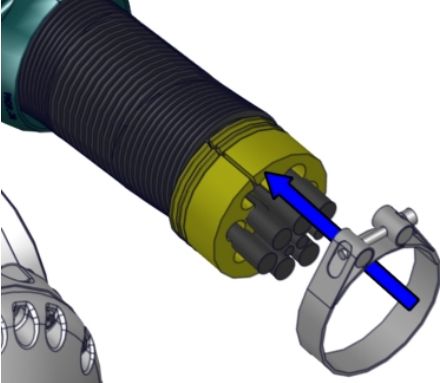
	Action	Note
2	<p>Arrange cable and hoses according to their position in the cable and hose retainer. Fit the retainer according to the marking made previously on the cables.</p>	 <p>xx2300001307</p>
3	<p>Secure the cable and hose retainer with the hose clamp. Tighten the screw so that the cables can not move.</p> <p> <b>CAUTION</b></p> <p>Make sure the fillers stay in the empty positions in the retainer.</p> <p> <b>CAUTION</b></p> <p>Handle the Ethernet cable with care. Do not pull more than 130 N.</p>	 <p>xx2300001308</p>

Step 4 - Cable package

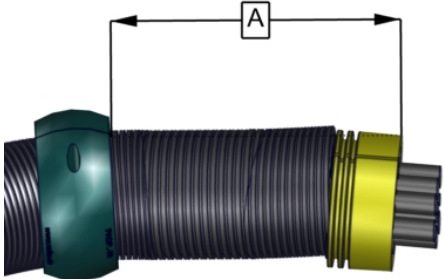

	Action	Note
1	<p>At the end of the cable package, move the protective sleeve so that the distance A between the sleeve and the cable retainer end is 170 mm.</p>	 <p>xx2300001242</p>

Continues on next page

## 5 Repair

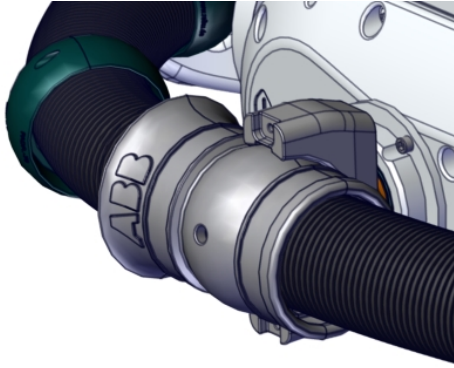

### 5.4.2 Replacing the protection hose for LeanID MH cable package

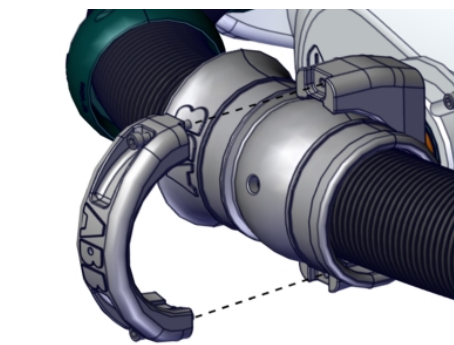
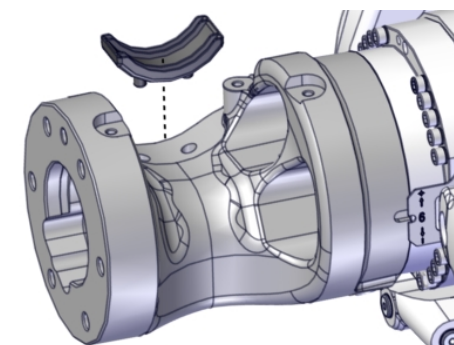
Continued

	Action	Note
2	<p>Place the cable package at the ball joint housing at the wrist bearing.</p> <p>Make sure that the hose reinforcement funnel is fitted correctly, in the direction shown in the figure.</p>	 <p>xx2100002710</p>
3	<p>Secure the cable package in the ball joint housing on the wrist.</p> <p> <b>Note</b></p> <p>Be careful not to lose the small o-ring on the attachment screw. It keeps the screw from falling off the housing when removed.</p>	 <p>xx2100002711</p>
4	<p>Place the lower bracket of the axis-6 cable support to the process turning disc.</p>	 <p>xx2100002712</p>

Continues on next page

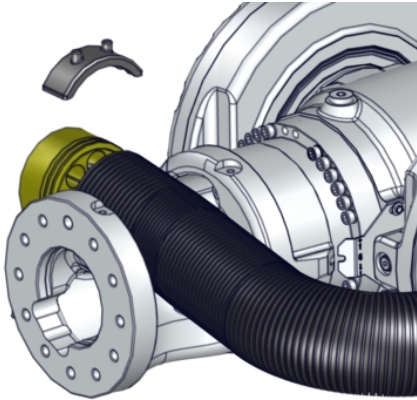
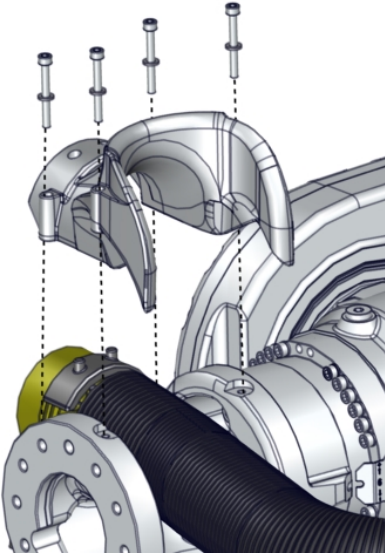
5.4.2 Replacing the protection hose for LeanID MH cable package  
Continued

	Action	Note
5	Place the cable package in the process turning disc and secure it with the upper bracket and the axis-6 cable support.	 <p data-bbox="970 745 1082 768">xx2300001210</p>  <p data-bbox="970 1361 1082 1384">xx2300001211</p> <p data-bbox="970 1395 1437 1489">Hex socket head cap screw: M6x50 Stainless steel A2-70 (4 pcs) Plain washer: 6.4x12x1.6 steel-A2F (4 pcs)</p>
6	 <b>CAUTION</b> When the cable package has been fitted on the upper arm, always check potential collision risks between the cable package and the wrist as well as between the cable package and any equipment fitted on the wrist, before restarting the normal production.	
7	Turn on the power and run the present programming at a <i>very slow</i> speed, while checking all movements for collision risk between cable package and wrist.	

Continues on next page

## 5 Repair

---

### 5.4.2 Replacing the protection hose for LeanID MH cable package

*Continued*

	Action	Note
8	<b>Only valid for Paramulti:</b> Connect the functional ground to the customer tool Profinet I/O and or tool changer to increase equipotential bonding.	
9	 <b>DANGER</b> Make sure all safety requirements are met when performing the first test run. See <a href="#">Test run after installation, maintenance, or repair on page 113</a> .	

## 6 Decommissioning

### 6.1 Environmental information

#### Introduction

ABB robots contain components in different materials. During decommissioning, all materials shall be dismantled, recycled, or reused responsibly, according to the relevant laws and industrial standards. Robots or parts that can be reused or upcycled helps to reduce the usage of natural resources.

#### Disposal symbol

The following symbol indicates that the product must not be disposed of as common garbage. Handle each product according to local regulations for the respective content (see table below).

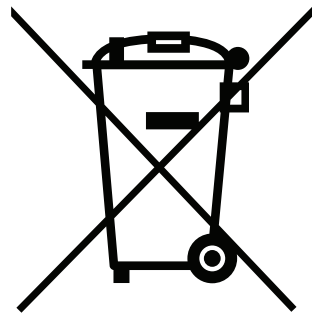

xx180000058

#### Materials used in the product

The table specifies some of the materials in the product and their respective use throughout the product.

Dispose components properly according to local regulations to prevent health or environmental hazards.

Material	Example application
Aluminium	Connectors, nuts
Brass, zink alloys	Connectors, pins, sockets
Copper	Cables, connectors, pins, sockets
Steel	Brackets, connection plate, screws
Thermo plastics (ETFE, PA, PC, PE, PET, POM, PP, PVC, TPE)	Connectors
Thermo setting polymers (CR, Epoxy, FKM, NBR, PUR)	Cable jackets, hoses, clamps, sealings

**This page is intentionally left blank**



# 7 Reference information

## 7.1 Introduction

---

### General

This chapter includes general information, complementing the more specific information in the different procedures in the manual.

## 7 Reference information

---

### 7.2 Unit conversion

### 7.2 Unit conversion

---

#### Converter table

Use the following table to convert units used in this manual.

Quantity	Units		
Length	1 m	3.28 ft.	39.37 in
Weight	1 kg	2.21 lb.	
Weight	1 g	0.035 ounces	
Pressure	1 bar	100 kPa	14.5 psi
Force	1 N	0.225 lbf	
Moment	1 Nm	0.738 lbf-ft	
Volume	1 L	0.264 US gal	

## 7.3 Screw joints

### General

This section describes how to tighten the various types of screw joints on ABB robots.

The instructions and torque values are valid for screw joints comprised of metallic materials and do *not* apply to soft or brittle materials.

### UNBRAKO screws

UNBRAKO is a special type of screw recommended by ABB for certain screw joints. It features special surface treatment (Gleitmo as described below) and is extremely resistant to fatigue.

Whenever used, this is specified in the instructions, and in such cases, *no other type of replacement screw* is allowed. Using other types of screws will void any warranty and may potentially cause serious damage or injury.

### Gleitmo treated screws

Gleitmo is a special surface treatment to reduce the friction when tightening the screw joint. It is recommended by ABB for M6-M20 screw joints. Screws treated with Gleitmo may be reused 3-4 times before the coating disappears. After this the screw must be discarded and replaced with a new one.

When handling screws treated with Gleitmo, protective gloves of nitrile rubber type should be used.

Generally, screws are lubricated with *Gleitmo 603* mixed with *Geomet 500* or *Geomet 702* in proportion 1:3. *Geomet* thickness varies according to screw dimensions, refer to the following.

Dimension	Lubricant	Geomet thickness
M6-M20 (any length except M20x60)	<i>Gleitmo 603 + Geomet 500</i>	3-5 µm
M6-M20 (any length except M20x60)	<i>Gleitmo 603 + Geomet 720</i>	3-5 µm
M20x60	<i>Gleitmo 603 + Geomet 500</i>	8-12 µm
M20x60	<i>Gleitmo 603 + Geomet 720</i>	6-10 µm

### Screws lubricated in other ways

Screws lubricated with Molykote 1000 or Molykote P1900 should *only* be used when specified in the repair, maintenance or installation procedure descriptions.

In such cases, proceed as follows:

- 1 Apply lubricant to the screw thread.
- 2 Apply lubricant between the plain washer and screw head.
- 3 Screw dimensions of M8 or larger must be tightened with a torque wrench. Screw dimensions of M6 or smaller may be tightened without a torque wrench *if* this is done by trained and qualified personnel.

*Continues on next page*

## 7 Reference information

### 7.3 Screw joints

Continued

Lubricant	Article number
Molykote 1000 (molybdenum disulphide grease)	3HAC042472-001
Molykote P1900 (molybdenum disulphide grease)	3HAC070875-001

#### Tightening torque

Before tightening any screw, note the following:

- Determine whether a **standard** tightening torque or **special** torque is to be applied. The **standard torques** are specified in the following tables. Any **special torques** are specified in the repair, maintenance or installation procedure descriptions. **Any special torque specified overrides the standard torque!**
- Use the *correct tightening torque* for each type of screw joint.
- Only use *correctly calibrated* torque keys.
- *Always tighten the joint by hand*, and never use pneumatic tools.
- Use the *correct tightening technique*, that is *do not* jerk. Tighten the screw in a slow, flowing motion.
- Maximum allowed total deviation from the specified value is **10%!**

#### Tightening torque for oil-lubricated screws with slotted or cross-recess head screws

The following table specifies the recommended standard tightening torque for *oil-lubricated screws with slotted or cross-recess head screws*.



#### Note

A special torque specified in the repair, maintenance or installation procedure overrides the standard torque.

#### Tightening torque for oil-lubricated screws with allen head screws

The following table specifies the recommended standard tightening torque for *oil-lubricated screws with allen head screws*.



#### Note

A special torque specified in the repair, maintenance or installation procedure overrides the standard torque.

Dimension	Tightening torque (Nm) Class 8.8, oil-lubricated	Tightening torque (Nm) Class 10.9, oil-lubricated	Tightening torque (Nm) Class 12.9, oil-lubricated
M5	6	-	-
M6	10	-	-
M8	24	34	40
M10	47	67	80
M12	82	115	140
M16	200	290	340
M20	400	560	670

Continues on next page

Dimension	Tightening torque (Nm) Class 8.8, oil-lubricated	Tightening torque (Nm) Class 10.9, oil-lubricated	Tightening torque (Nm) Class 12.9, oil-lubricated
M24	680	960	1150

Tightening torque for lubricated screws (Molykote, Gleitmo or equivalent) with allen head screws  
The following table specifies the recommended standard tightening torque for *screws lubricated with Molykote 1000, Gleitmo 603 or equivalent with allen head screws.*

**Note**

A special torque specified in the repair, maintenance or installation procedure overrides the standard torque.

Dimension	Tightening torque (Nm) Class 10.9, lubricated <sup>i</sup>	Tightening torque (Nm) Class 12.9, lubricated <sup>i</sup>
M5		8
M6		14
M8	28	35
M10	55	70
M12	96	120
M16	235	300
M20	460	550
M24	790	950

<sup>i</sup> Lubricated with Molykote 1000, Gleitmo 603 or equivalent

**Water and air connectors**

The following table specifies the recommended standard tightening torque for *water and air connectors.*

**Note**

A special torque specified in the repair, maintenance or installation procedure overrides the standard torque.

Dimension	Material	Tightening torque Nm - Nominal	Tightening torque Nm - Min.	Tightening torque Nm - Max.
ALL	Mixed	The lower tightening torque of the two materials.		
1/8	Brass only	12	8	15
1/4	Brass only	15	10	20
3/8	Brass only	20	15	25
1/2	Brass only	40	30	50
1/2	Stainless steel only	49	47	59
3/4	Brass only	70	55	90

## 7 Reference information

---

### 7.4 Weight specifications

### 7.4 Weight specifications

---

#### Definition

In installation, repair, and maintenance procedures, weights of the components handled are sometimes specified. All components exceeding 22 kg (50 lbs) are highlighted in this way.

To avoid injury, ABB recommends the use of a lifting accessory when handling components with a weight exceeding 22 kg. A wide range of lifting accessories and devices are available for each manipulator model.

---

#### Example

Following is an example of a weight specification in a procedure:

	Action	Note
	 <b>CAUTION</b> The arm weighs 25 kg. All lifting accessories used must be sized accordingly.	

## 7.5 Toolkits, DressPack

### General

All service (repair, maintenance and installation) instructions contain lists of tools required to perform the specified activity. All special tools, that is all tools that are not considered standard as defined below, are listed in their instructions respectively.

This way, the tools required are the sum of the Standard Toolkit and any tools listed in the instruction.

### Standard toolkit

This standard toolkit contains a set of standard tools used for DressPack, 3HAC17290-7.

Qty	Article number	Tool	Note
1	-	Socket head cap, 5-17mm	-
1	-	Torx socket no: 20-60	-
1	-	Phillips screwdriver, small	For Harting connectors
1	-	Flat screwdriver, medium	For Harting connectors
2	-	Ring-open-end spanner 8-19 mm	For water connectors on water and air unit
1	-	Open end wrench, 27 mm.	For Tension arm unit and water connectors on DressPack
1	-	Open end wrench, 36 mm	For water connectors on DressPack

### Toolkit, cables

This toolkit contains tools needed for work with cables:

Qty	Article number	Tool	Note
1	0999 000 0171 (D-sub)	Removal and Insertion tool for pins and sockets	Art. no. from Harting
1	0999 000 0012 (HAN DD)	Removal tool for pins and sockets	Art. no. from Harting
1	0999 000 0319 (HAN EE)	Removal tool for pins and sockets	Art. no. from Harting
1	0999 000 0059 (HAN DD and HAN EE)	Insertion tool for pins and sockets	Art. no. from Harting
1	-	Stripping pliers	
1	09 99 000 0021	Crimping tool HARTING with locator	Art. no. from Harting
1	09 99 000 0001	Crimping tool BUCHANAN, HARTING	Art. no. from Harting
1	09 99 000 0175 09 99 000 0169	Crimping tool HARTING	Art. no. from Harting

*Continues on next page*

## 7 Reference information

---

### 7.5 Toolkits, DressPack

*Continued*

Qty	Article number	Tool	Note
1	09 99 000 0646 (article number at Harting Techno- logy Group)	M12 dynamometric screwdriver SW15 Torque tool for Ethernet connectors  xx2200001261	Art. no. from Harting



## 7.6 Lifting accessories and lifting instructions

---

### General

Many repair and maintenance activities require different pieces of lifting accessories, which are specified in each procedure.

The use of each piece of lifting accessories is *not* detailed in the activity procedure, but in the instruction delivered with each piece of lifting accessories.

The instructions delivered with the lifting accessories should be stored for later reference.

**This page is intentionally left blank**

## 8 Spare parts

### 8.1 Introduction

---

#### General

This chapter contains more specific article information. It is to be regarded as a complement to the slightly generic procedure information found in the Installation, Maintenance and Repair chapters.

## 8 Spare parts

### 8.2 DressPack lower arm MH cable package

### 8.2 DressPack lower arm MH cable package

#### Spare parts - lower arm MH

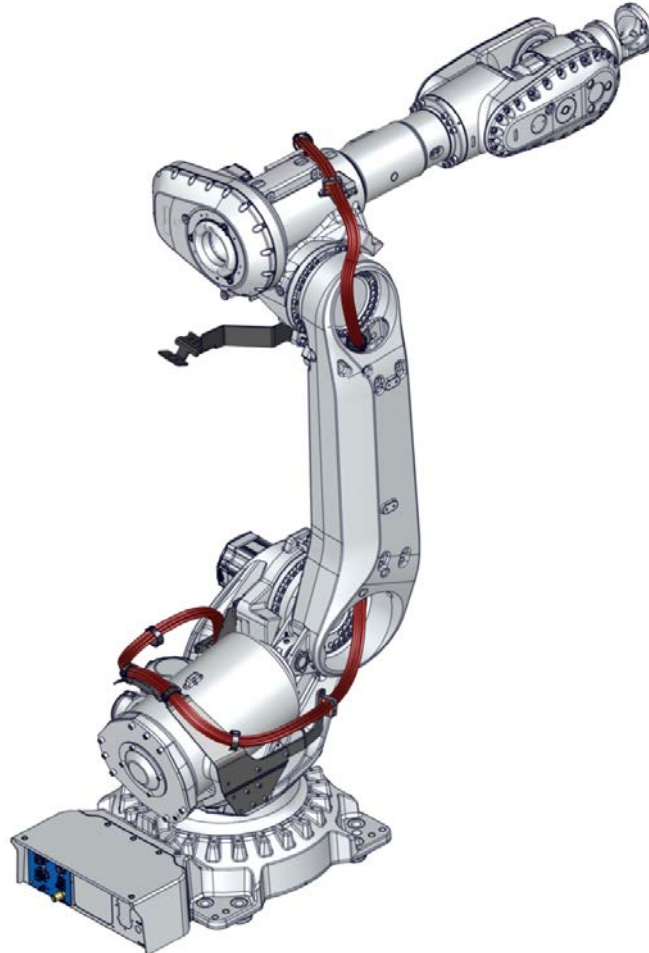

xx2300001074



#### Note

No velcro strap included in spare part delivery. Reuse velcro strap from old cable package.

Spare part	Article number	Note	Level
Harness lower arm MH Para-com	3HAC083476-001	Parallel. All attachments except velcro straps included.	
Harness lower arm MH Paramulti	3HAC083482-001	EtherNet. All attachments except velcro straps included.	

### 8.3 DressPack lower arm SW cable package

#### Spare parts - lower arm SW

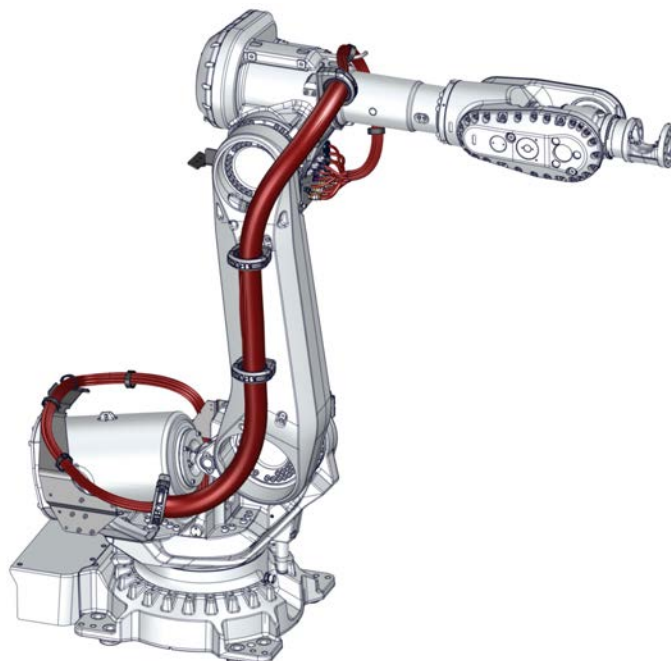

xx2300001045



#### Note

No velcro strap included in spare part delivery. Reuse velcro strap from old cable package.

Spare part	Article number	Note	Level
Harness lower arm SW Parallel-Servo	3HAC086512-001	Parallel-Servo. All attachments except velcro straps included.	
Harness lower arm SW Paramulti-Servo	3HAC086514-001	EtherNet-Servo. All attachments except velcro straps included.	

## 8 Spare parts

### 8.4 DressPack upper arm MH3 cable package

### 8.4 DressPack upper arm MH3 cable package

#### Spare parts - upper arm MH3

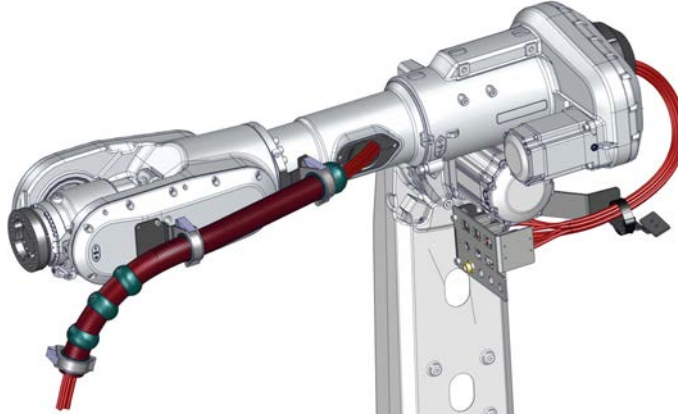

xx2300001106



#### Note

No velcro strap included in spare part delivery. Reuse velcro strap from old cable package.

Spare part	Article number	Note	Level
Harness upper arm MH3 Paracom	IRB 6710-210/2.65: 3HAC083533-001 IRB 6710-200/2.95: 3HAC083534-001	Parallel. All attachments except velcro straps included.	
Harness upper arm MH3 Paramulti	IRB 6710-210/2.65: 3HAC083539-001 IRB 6710-200/2.95: 3HAC083540-001	EtherNet. All attachments except velcro straps included.	

## 8.5 DressPack LeanID MH cable package

## Spare parts - LeanID MH

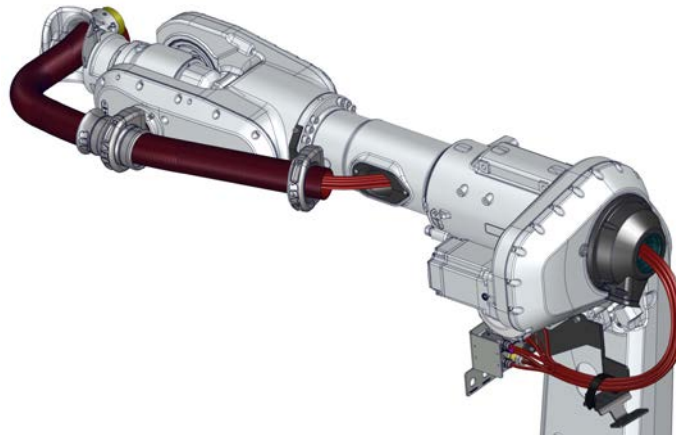

xx2300001108

**Note**

No velcro strap included in spare part delivery. Reuse velcro strap from old cable package.

Spare part	Article number	Note	Level
Harness upper arm LeanID MH Paracom	<b>IRB 6710-175/2.65 LID:</b> 3HAC083515-001	Parallel. All attachments except velcro straps included.	
	<b>IRB 6710-175/2.95 LID:</b> 3HAC083516-001		
Harness upper arm LeanID MH Paramulti	<b>IRB 6710-175/2.65 LID:</b> 3HAC083521-001	EtherNet. All attachments except velcro straps included.	
	<b>IRB 6710-175/2.95 LID:</b> 3HAC083522-001		

## 8 Spare parts

### 8.6 DressPack LeanID SW cable package

### 8.6 DressPack LeanID SW cable package

#### Spare parts - LeanID SW

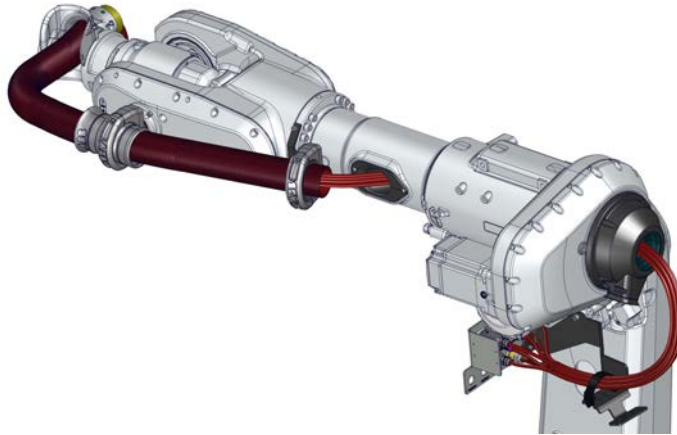

xx2300001108



#### Note

No velcro strap included in spare part delivery. Reuse velcro strap from old cable package.

Spare part	Article number	Note	Level
Harness upper arm LeanID SW Paracom Servo	IRB 6710-175/2.65 LID: 3HAC086529-001	Parallel-Servo. All attachments except velcro straps included.	
	IRB 6710-175/2.95 LID: 3HAC086530-001		
Harness upper arm LeanID SW Paramulti Servo	IRB 6710-175/2.65 LID: 3HAC086533-001	EtherNet-Servo. All attachments except velcro straps included.	
	IRB 6710-175/2.95 LID: 3HAC086534-001		



---

## 8.7 Connection kits

---

### Spare parts - connector kits

Spare part	Article number	Note	Level
CP/CS bus, Proc 1 on base	3HAC087283-001	Base	
FB7 on base	3HAC023441-001	Base	
Weld, Proc 1-4	3HAC17201-1	Base	
CP/CS bus, Proc 1	3HAC087285-001	Axis 3	
CP/CS, Proc 1, Servo & FB	3HAC087286-001	Axis 3	
CP/CS bus, Proc 1	3HAC087288-001	Axis 6	
CP/CS, Proc 1, Servo & FB	3HAC087289-001	Axis 6	
Weld, Proc	3HAC087347-001	Axis 6	

## 8 Spare parts

---

### 8.8 DressPack floor

### 8.8 DressPack floor

---

#### Spare parts - Floor process cables

Spare part	Article number	Note	Level
Parallel cable CP/CS 7 m	3HAC089711-001		
Parallel cable CP/CS 15 m	3HAC089711-002		
Parallel cable CP/CS 22 m	3HAC089711-003		
Parallel cable CP/CS 30 m	3HAC089711-004		
DeviceNet cable CP/CS 7 m	3HAC022978-001		
DeviceNet cable CP/CS 15 m	3HAC022978-002		
DeviceNet cable CP/CS 22 m	3HAC022978-006		
DeviceNet cable CP/CS 30 m	3HAC022978-003		
EtherNet cable 7 m	3HAC079476-001		
EtherNet cable 15 m	3HAC079476-002		
EtherNet cable 22 m	3HAC079476-003		
EtherNet cable 30 m	3HAC079476-004		

# Index

## A

allergenic material, 23  
aluminum  
  disposal, 171  
assembly instructions, 31  
assessment of hazards and risks, 23  
attachments LeanID MH /LeanID SW  
  fitting, 49  
attachments MH3  
  fitting, 43

## C

cabinet lock, 23  
carbon dioxide extinguisher, 24  
climbing on robot, 26  
copper  
  disposal, 171

## E

environmental information, 171

## F

fire extinguishing, 24  
fitting  
  attachments LeanID MH /LeanID SW, 49  
  attachments MH3, 43

## H

hanging  
  installed hanging, 23  
hazard levels, 15  
hazardous material, 171  
height  
  installed at a height, 23  
hot surfaces, 26  
HRA, 23

## I

installing  
  process turning disc, 55  
instructions for assembly, 31  
integrator responsibility, 23

## L

labels  
  robot, 16  
lifting accessory, 178  
limitation of liability, 13  
lock and tag, 23

## N

national regulations, 23

## O

original spare parts, 13

## P

pedestal  
  installed on pedestal, 23  
personnel  
  requirements, 14  
PPE, 14  
process turning disc  
  installing, 55  
protective equipment, 14  
protective wear, 14

## R

recycling, 171  
regional regulations, 23  
replacements, report, 127  
report replacements, 127  
responsibility and validity, 13  
risk of burns, 26  
robot  
  labels, 16  
  symbols, 16

## S

safety  
  fire extinguishing, 24  
  signals, 15  
  signals in manual, 15  
  symbols, 15  
  symbols on robot, 16  
  test run, 113  
safety devices, 24  
safety signals  
  in manual, 15  
screw joints, 175  
signals  
  safety, 15  
steel  
  disposal, 171  
symbols  
  safety, 15  
system integrator requirements, 23

## T

thermo plastics  
  disposal, 171  
thermo setting polymers  
  disposal, 171  
troubleshooting  
  safety, 27

## U

upcycling, 171  
users  
  requirements, 14

## V

validity and responsibility, 13







**ABB AB**

**Robotics & Discrete Automation**

S-721 68 VÄSTERÅS, Sweden

Telephone +46 10-732 50 00

**ABB AS**

**Robotics & Discrete Automation**

Nordlysvegen 7, N-4340 BRYNE, Norway

Box 265, N-4349 BRYNE, Norway

Telephone: +47 22 87 2000

**ABB Engineering (Shanghai) Ltd.**

Robotics & Discrete Automation

No. 4528 Kangxin Highway

PuDong New District

SHANGHAI 201319, China

Telephone: +86 21 6105 6666

**ABB Inc.**

**Robotics & Discrete Automation**

1250 Brown Road

Auburn Hills, MI 48326

USA

Telephone: +1 248 391 9000

**[abb.com/robotics](http://abb.com/robotics)**